

DESIGN via ROOT LOCUS

In this chapter you will learn the following :

- ❖ How to use the root locus to design cascade compensators to improve the steady-state error
- ❖ How to use the root locus to design cascade compensators to improve the transient response
- ❖ How to use the root locus to design cascade compensators to improve both the transient response and steady-state error
- ❖ How to use the root locus to design feedback compensators to improve the transient response
- ❖ How to realize the designed compensators physically

The root locus allows us to choose the proper loop gain to meet a transient response specification. As the gain varied, we move through different region of response. But we are limited to responses that exists along to root locus.

We **compansate** the system with additional poles and zeros, so that the compansated system has a root locus that goes through the desired pole location for some value of gain. Compansators are also used to improve the steady state error characteristics. Generally, the transient response is improved with the addition of differetiation, and the stesdy state error is improved with the addition of integration in the forward path.

Two configration of compansation are covered in this lecture : Cascade compansation and feedback compansation as modeled in the following figures. In the cascade

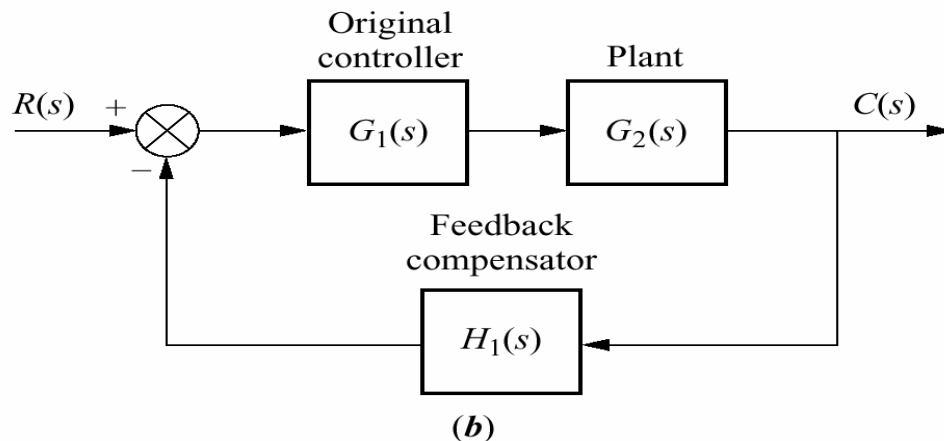
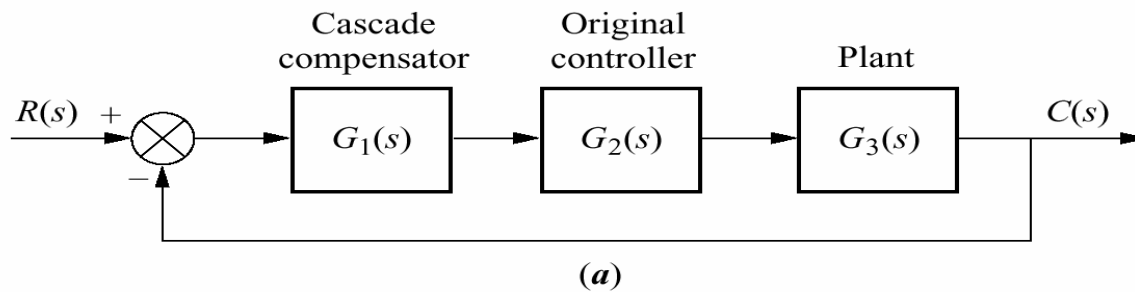

compansation, the compansating network, $G_1(s)$, is placed at the low-power end of the forward path in cascade with the plant. If feedback compansation is used, the compansator, $H_1(s)$ is placed in the feedback path. Both methods change the open loop poles and zeros, thereby creating a new root locus that goes through the desired closed loop pole location.

Compensators that use pure integration for improving steady state error or pure differentiation for improving the transient response are defined as ***ideal compensators***. Ideal compensators must be implemented with active networks, which, in the case of electrical networks, require the use of active amplifiers and possible additional power sources. An advantage of ideal compensators is that steady state error is reduced to zero. Electromechanical ideal compensators, such as tachometers, are often used to improve transient response.

Other design techniques that preclude the use of active devices for compensation can be adopted. These compensators, which can be implemented with passive elements such as resistors and capacitors, do not use pure integration and differentiation and are not ideal compensators. Advantages of passive networks are that they are less expensive and do not require additional power sources for their operations. Their disadvantage is that the steady state error is not driven to zero in cases where ideal compensators yield zero error.

Thus the choice between an active or passive compensator revolves around the cost, weight, desired performance, transfer function. We first discuss cascade compensator design using the ideal compensation and follow with cascade compensation using compensators that are not implemented with pure integration and differentiation.

Improving the Steady-State error via Cascade Compensation

We will discuss two ways to improve the steady state error using cascade compensation

1) Ideal Integral Compensation (PI) : Steady-state error can be improved by placing an open loop pole at the origin. A compensator with a pole at the origin and a zero close to the pole is called ideal compensator. In the following example, we demonstrate the effect of ideal integral compensation. An open loop pole will drive the steady state error to zero. An open loop zero will be placed very close to the open loop pole at the origin so that the original closed loop poles on the original root locus still remain at approximately the same points on the compensated root locus.

Example : Given the system of figure(a), operating a damping ratio of 0.174, show that the addition of the integral compensator shown in figure(b) reduces the steady state error to zero for a step input without appreciably affecting transient response.

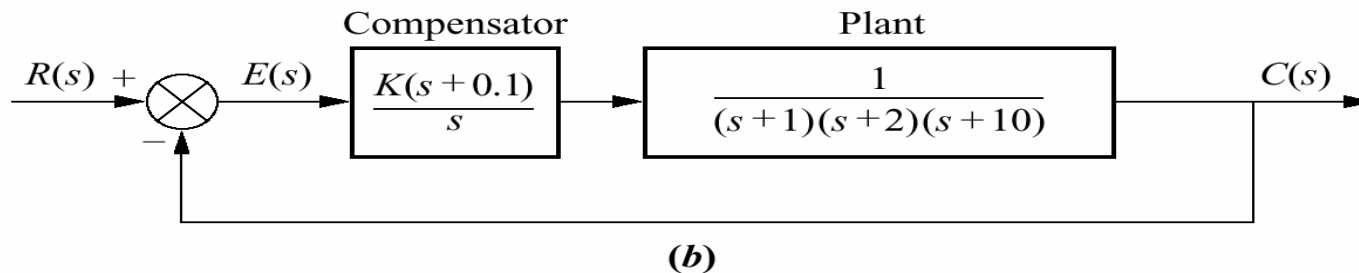
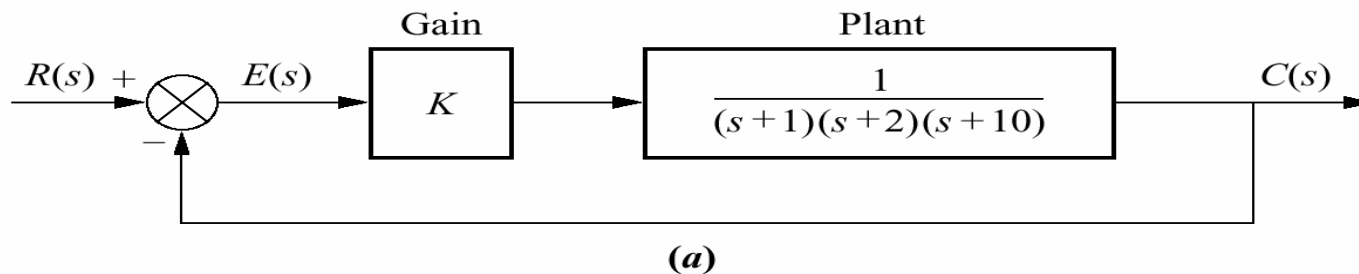

Solution : We first analyze the uncompensated system and determine the location of dominant second order poles. Next we evaluate the uncompensated steady state error for a unit step input. The root locus of uncompensated system is shown in following figure.

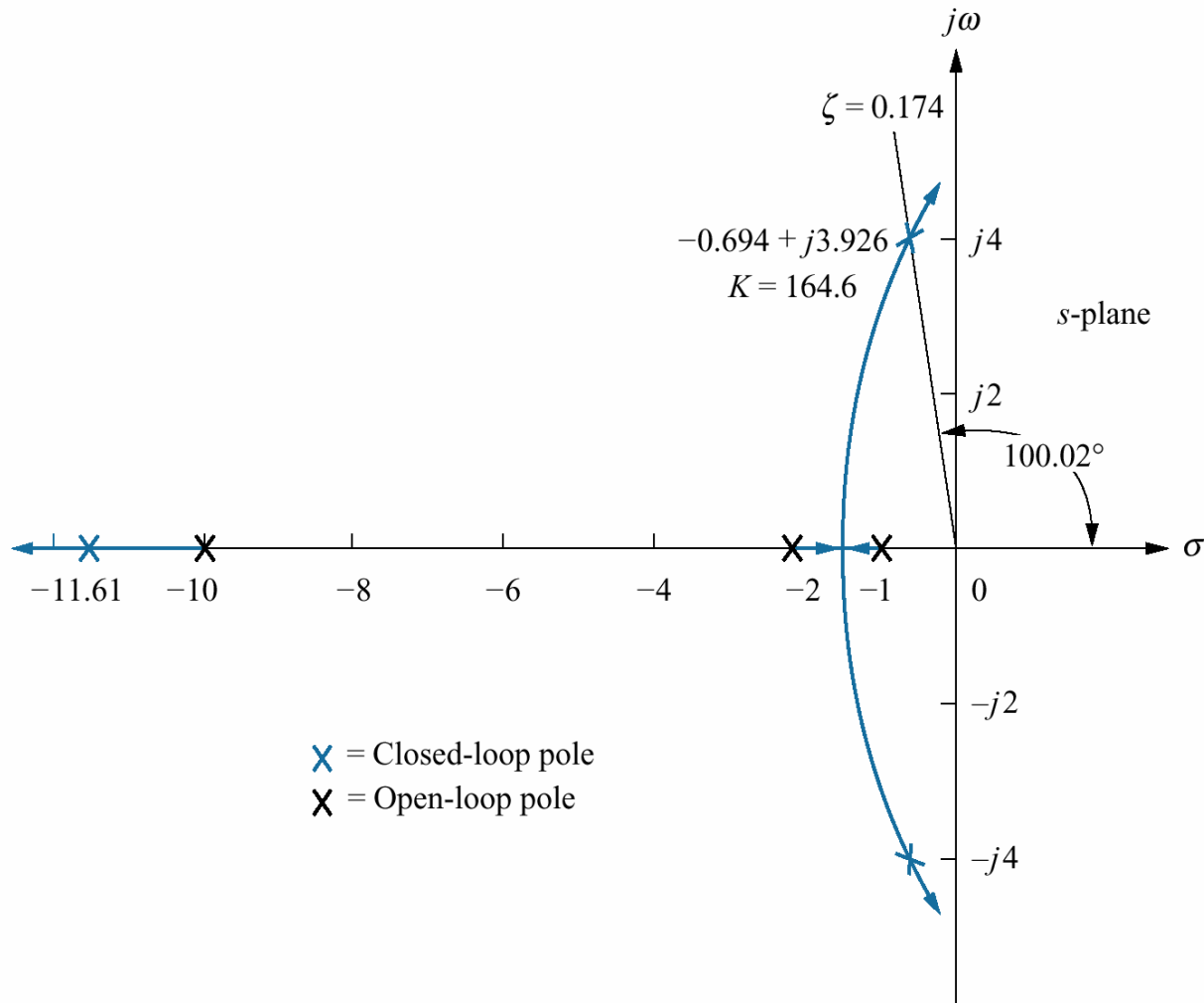

Adding an integral compensator with a zero at 0.1 as shown in the figure, we obtain the root locus as shown in other figure.

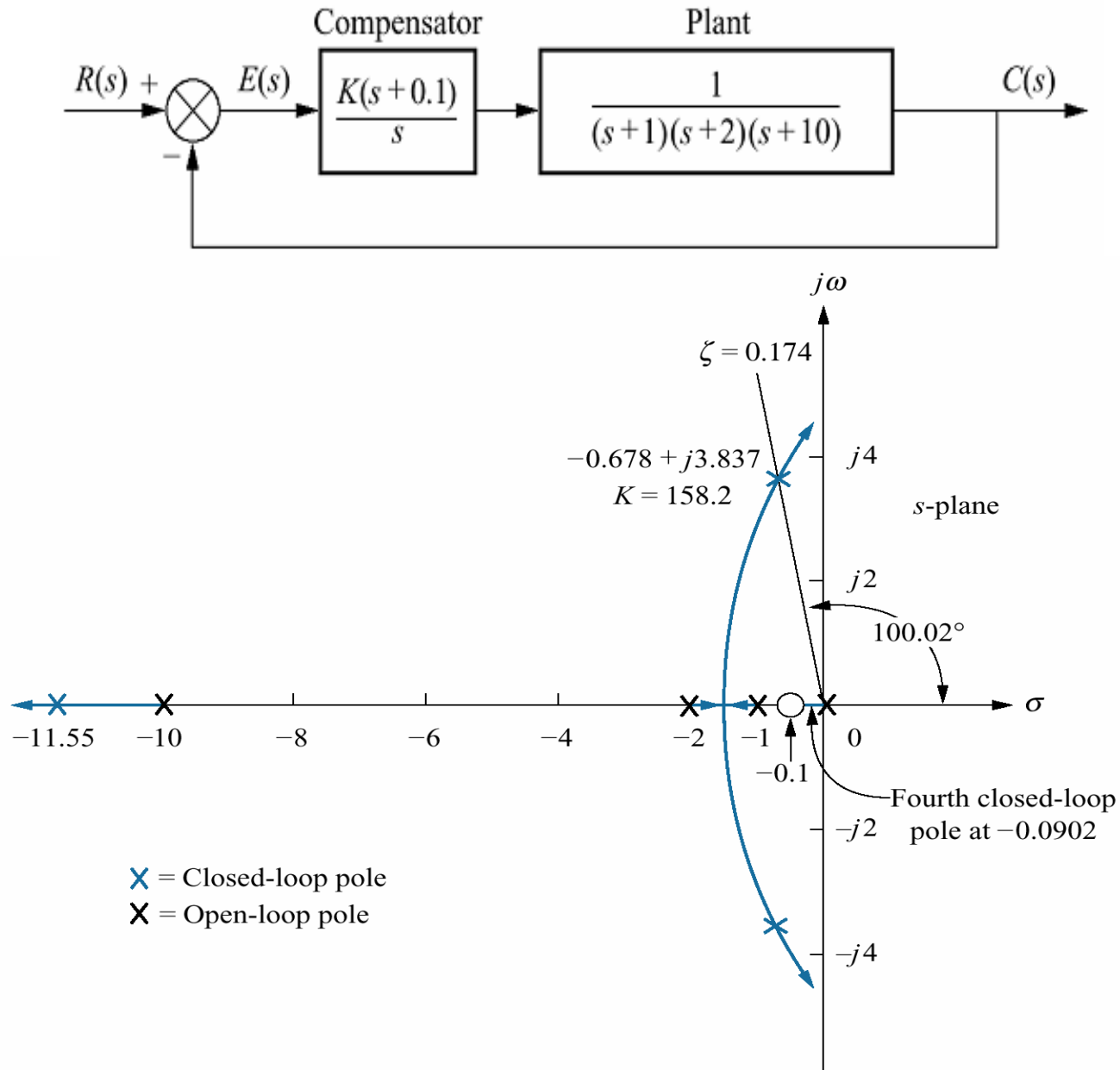

Following figure compares the uncompensated response with ideal integral compensated response. The step response of ideal integral compensated system approaches unity in steady state, while uncompensated system approaches 0.892. **Thus the ideal integral compensated system responds with zero steady state error. But the transient responses for two cases are similar.**

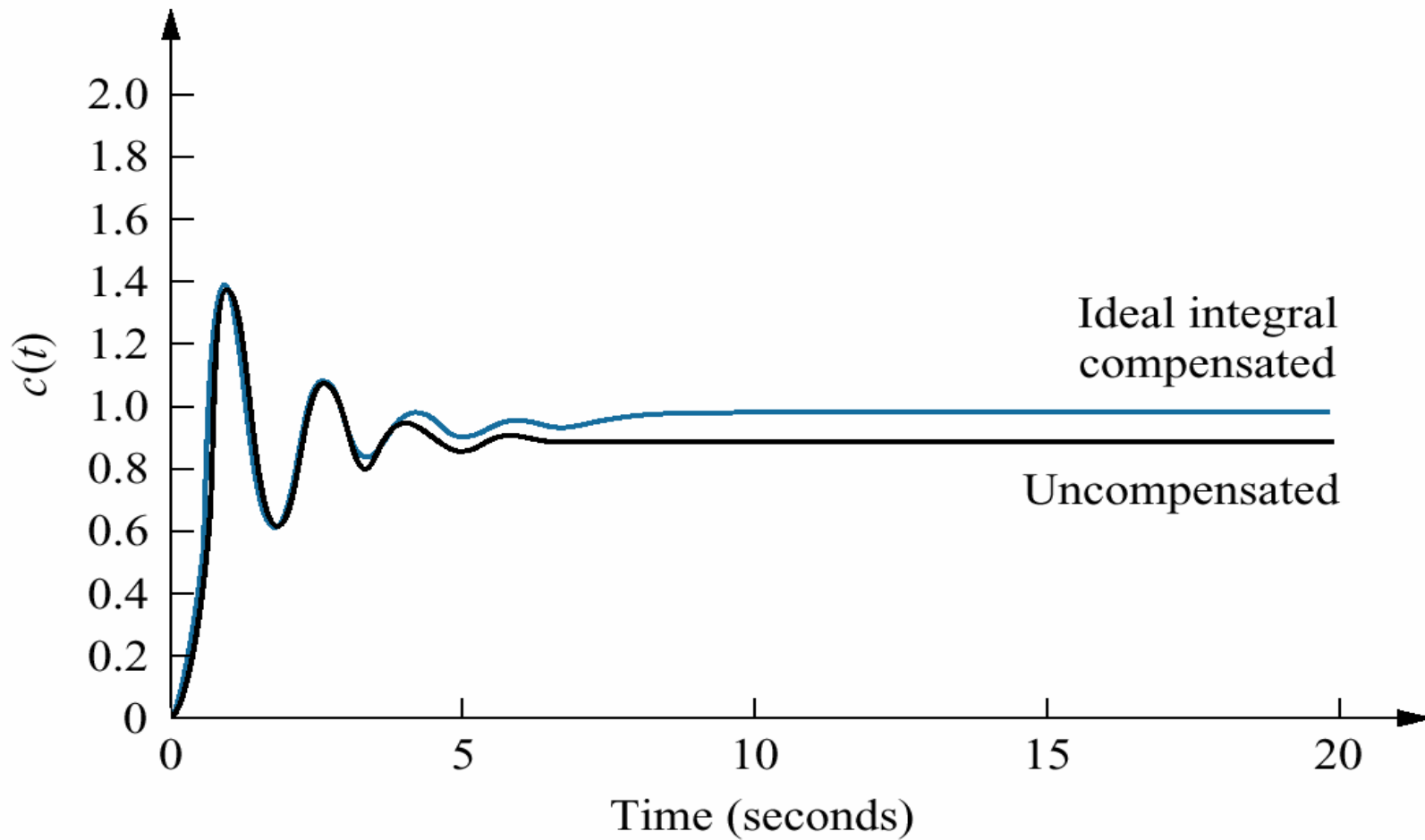

2) Lag Compensation : Ideal integral compensator requires an active integrator. But as we will see later, circuit configuration for the lag compensator can be obtained with passive networks and thus do not require the active amplifiers and possible additional power sources. However, lag compensators can not drive the steady-state error to zero. But very small steady state error can be obtained. The configuration and transfer function of lag compensators shown in following figure.

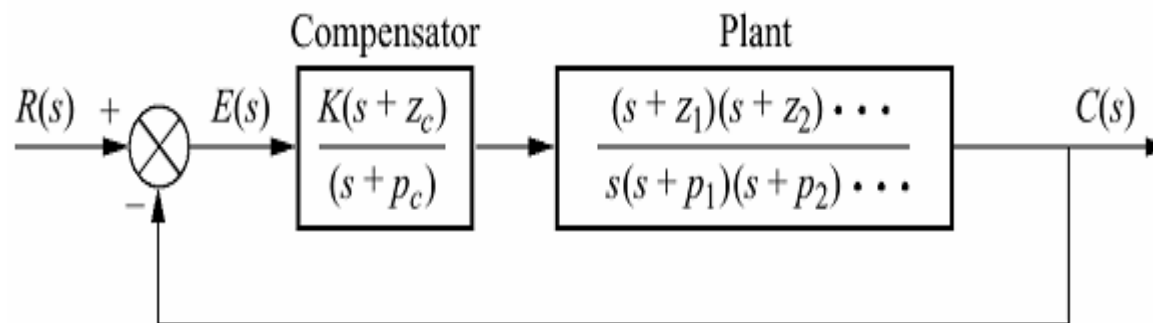

Example : Compensate the system of previous example to improve the steady –state error by a factor of 10 if the system is operating with a damping ratio of 0.174.

Solution : Remember that steady state error of uncompensated system is 0.108 with a gain $K=8.23$. From the problem statement, $e(\infty)=0.108/10=0.0108$. If we want to design a lag compensator, the following algorithm can be used to select K , z_c and p_c conventionally. Using the formulation for steady state error which we have learned in the lecture “Steady-State Errors”, we can find the value of K as follow:

$$e(\infty) = \frac{1}{1+K} \Rightarrow K = \frac{1-e(\infty)}{e(\infty)} = \frac{1-0.0108}{0.0108} = 91.59$$

$$\frac{z_c}{p_c} = \frac{K_{new}}{K_{old}} = \frac{91.59}{8.23} = 11.13$$

Arbitrarily select $p_c=0.01$ and $z_c=11.13p_c\approx 0.111$. Let us compare the compensated system with uncompensated system as shown in following figure. Steady-state error of the uncompensated system is 0.108 while the compensated system has steady state error of 0.011.

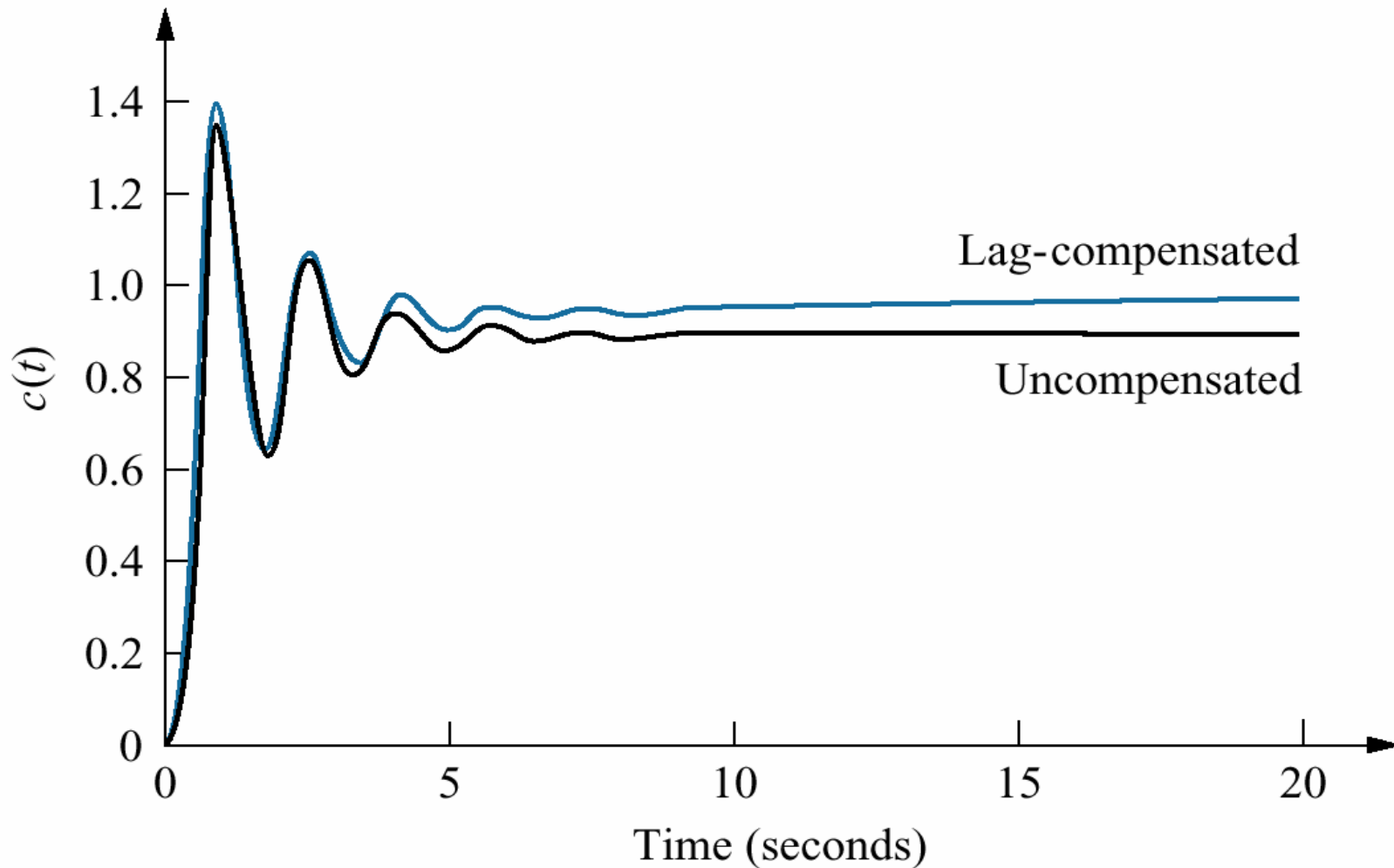

Improving Transient Response via Cascade Compensation

We will discuss two ways to improve transient response using cascade compensation.

1) Ideal Derivative Compensation (PD) : The transient response of a system can be selected by choosing an appropriate closed loop pole location on the s-plane. If this point is on the root locus, then a simple gain adjustment is all that is required in order to meet the transient response specification. A compensator whose transfer function $G_c(s) = s + z_c$, the sum of a differentiator and a pure gain, is called an *ideal derivative*, or *PD controller*.

Example : Given the system of following figure, design an ideal derivative compensator to yield a 16% overshoot, with a threefold reduction in settling time.

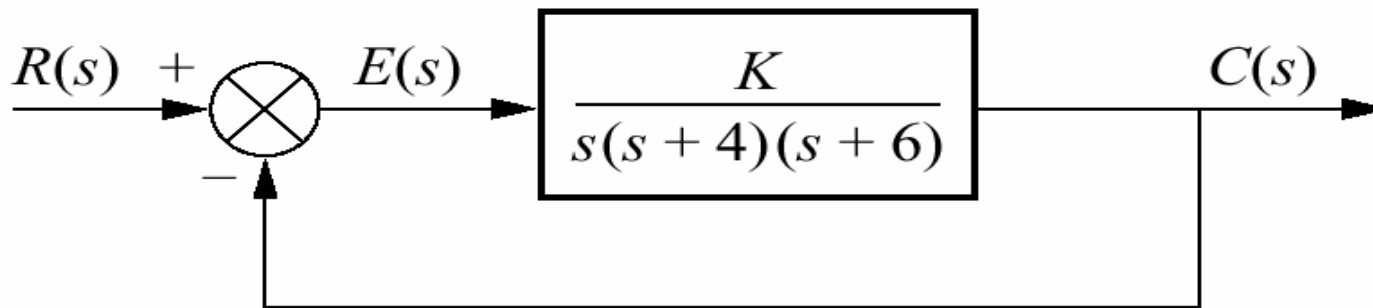

Solution : Let us first evaluate the performance of uncompensated system with 16% overshoot. Since 16% overshoot is equivalent to $\zeta=0.504$, we search along that damping ratio line for an odd multiple of 180° and find that the dominant, second order pair of poles is at $-1.205 \pm j2.064$. Thus the settling time of the uncompensated system is $T_s = 4/(\zeta\omega_n) = 3.320$. The root locus of uncompensated system is shown in following figure.

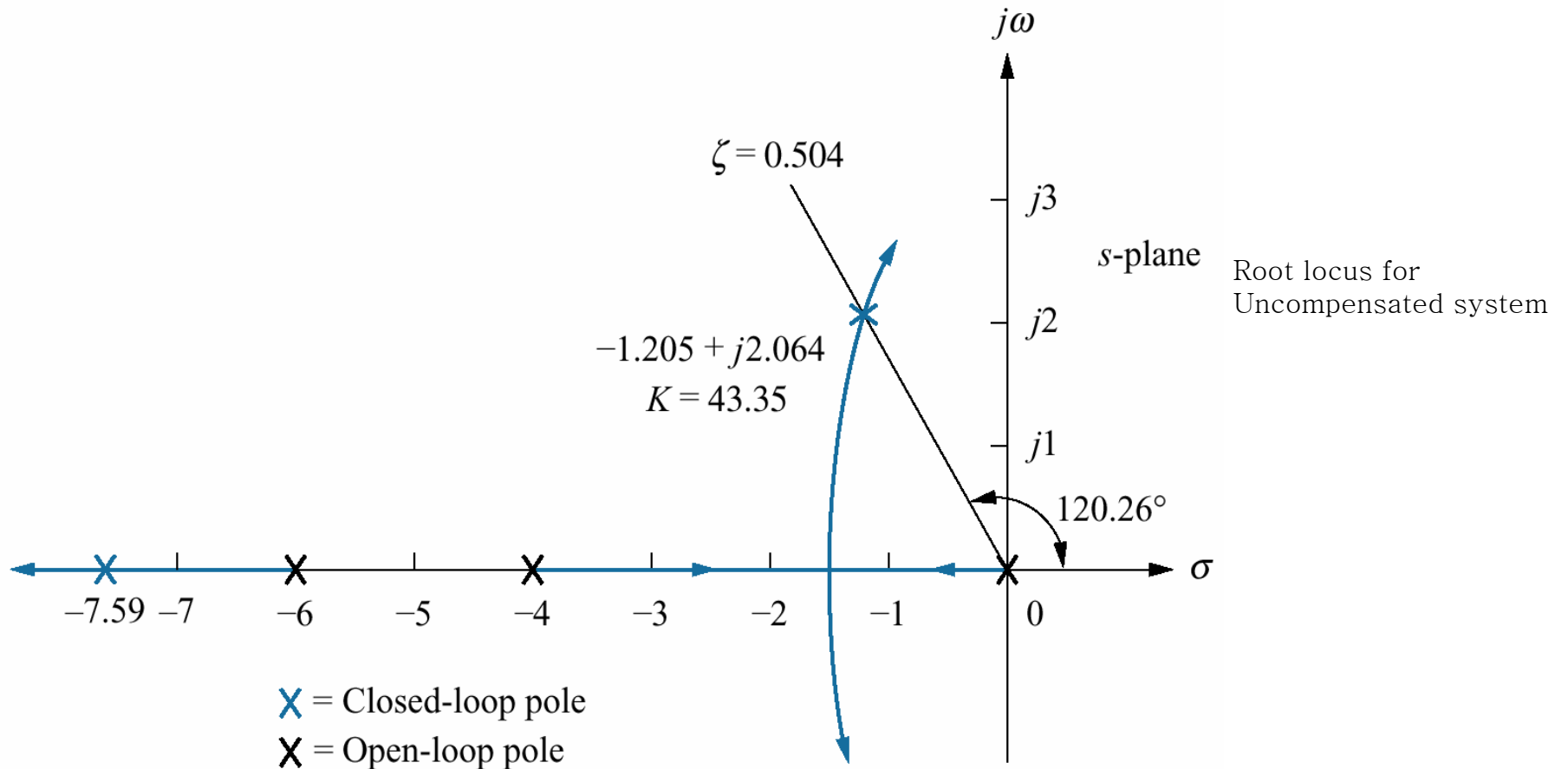

Now we proceed to compensate the system. First we find the location of the compensated system's dominant poles. In order to have a threefold reduction in the settling time, the compensated system's settling time will be 1.107. Therefore, real part of the compensated system dominant pole is

$$\sigma = \frac{4}{T_s} = \frac{4}{1.107} = 3.613$$

Following figure shows the designed dominant second order pole with a real part equal to -3.613 .

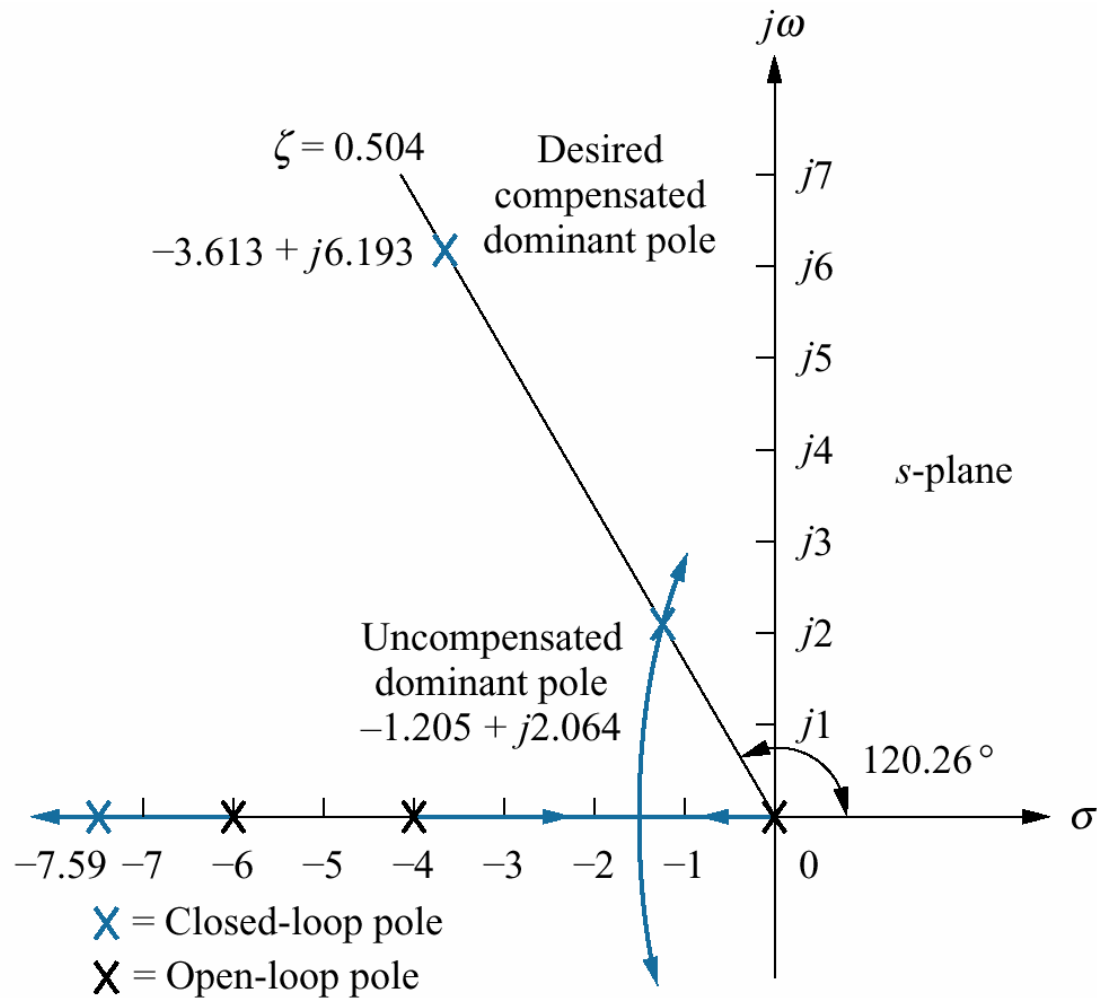

Therefore imaginary part of compensated system second order dominant pole is

$$\omega_d = 3.613 \tan(180^\circ - 120.26^\circ) = 6.193$$

Next we design the location of compensator zero. Using a computer code, such as the code extended to book's cd, input the uncompensated system poles and zeros and find the optimum value for zero. For this example, $\sigma=3$. Following figure shows the root locus of compensated system.

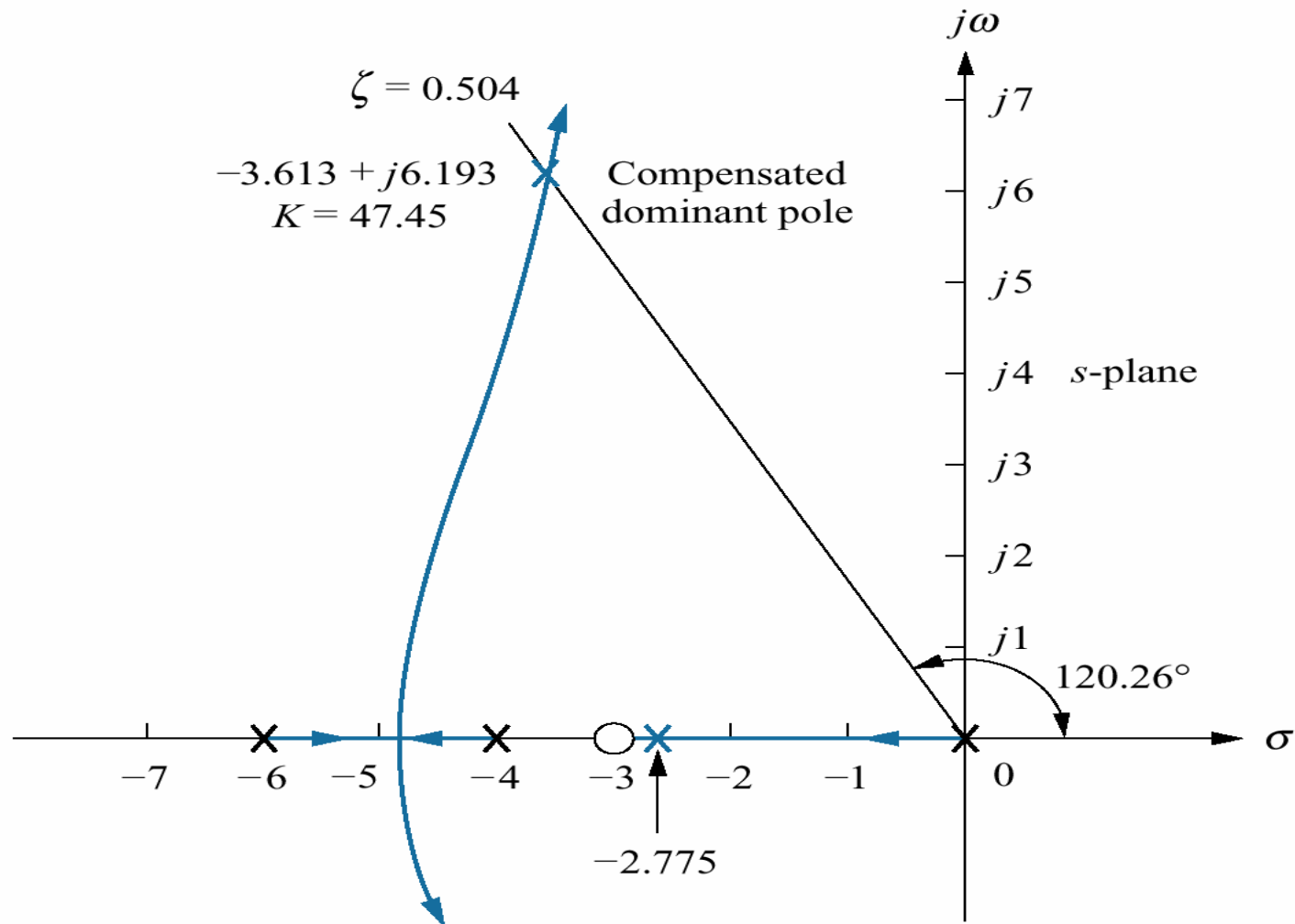

x = Closed-loop pole
 x = Open-loop pole

Following figure shows the step response and comparison result of compensated and uncompensated system

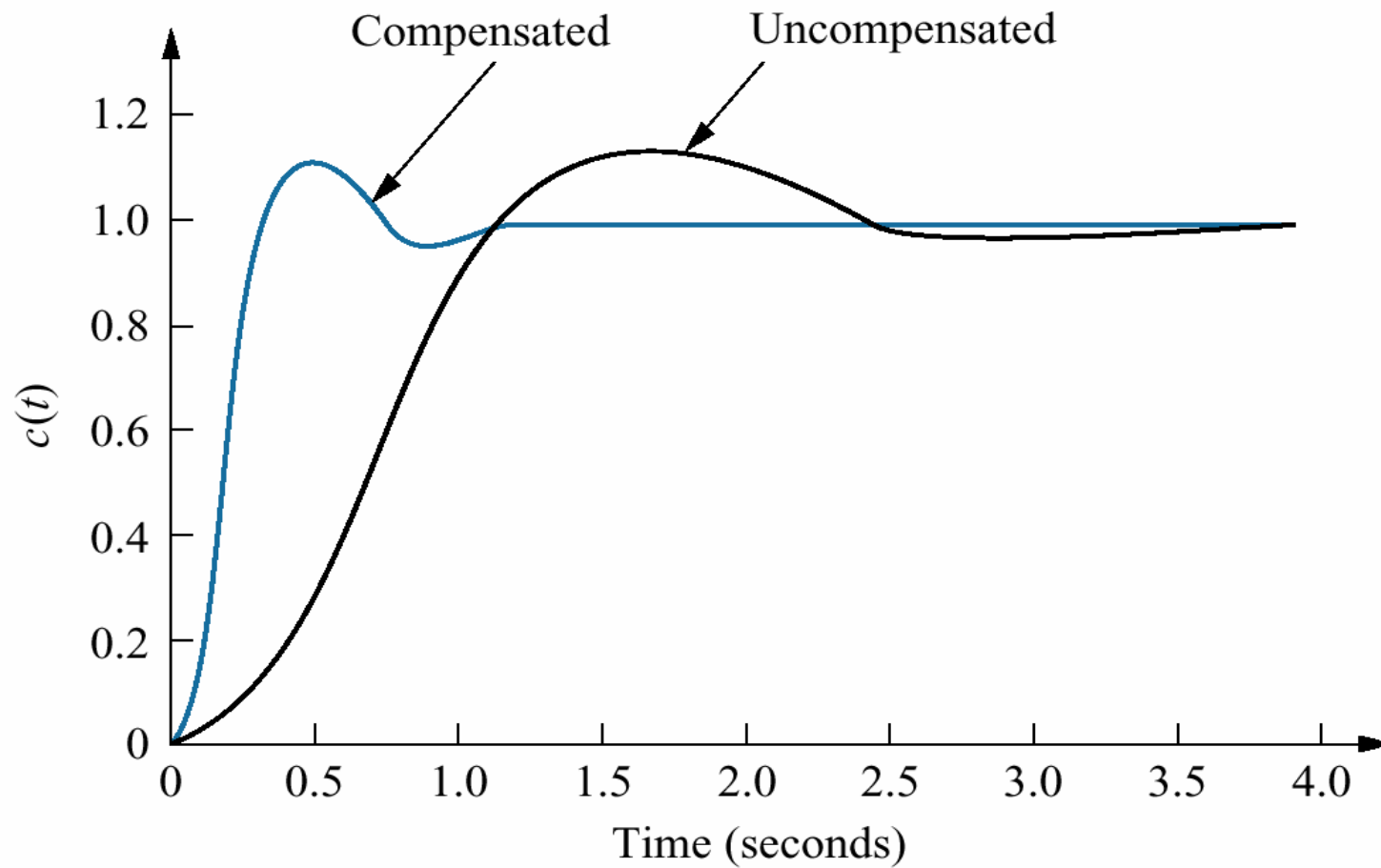

Block Diagram and Transfer Function of PD Controller : Once we decide on the location of the compensating zero, how do we implement the ideal derivative, or PD controller? The ideal integral compensator that improved steady-state error was implemented with a proportional-plus-integral (PI) controller. The ideal derivative compensator used to improve transient response is implemented with a proportional-plus-derivative (PD) controller. For example, in the following figure the transfer function of controller is

$$G_c(s) = K_2s + K_1 = K_2 \left(s + \frac{K_1}{K_2} \right)$$

Hence, K_1/K_2 is chosen to equal the negative of the compensator zero, and K_2 is chosen to contribute to the required loop gain value.

PD Controller

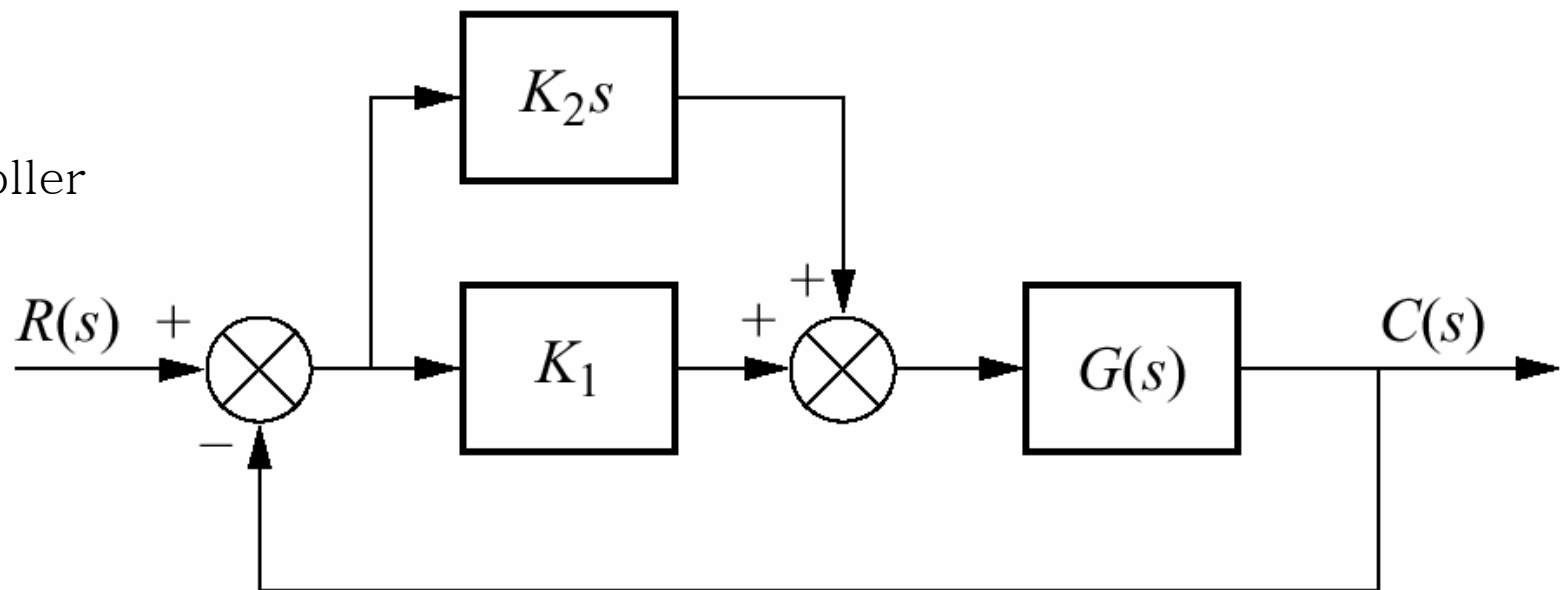

2) Lead Compensation : If we want to use passive elements instead of active ones, we must use the lead compensation to improve transient response. If we use the lead compensation, noise due to differentiation is reduced. Let us look at the concept behind lead compensation. If we select a desired dominant second order pole, the sum of the angles from the uncompensated system's poles and zeros to the design point can be found. The difference between 180° and the sum of angles must be angular contribution required of the compensator. For example, look at the figure below. We see that

$$\theta_2 - \theta_1 - \theta_3 - \theta_4 + \theta_5 = (2k+1)180^\circ$$

where $\theta_2 - \theta_1 = \theta_c$ is the angular contribution of the lead compensator. From the figure, we see that θ_c is the angle of a ray extending from the design point and intersecting the real axis at the pole value and zero value of the compensator.

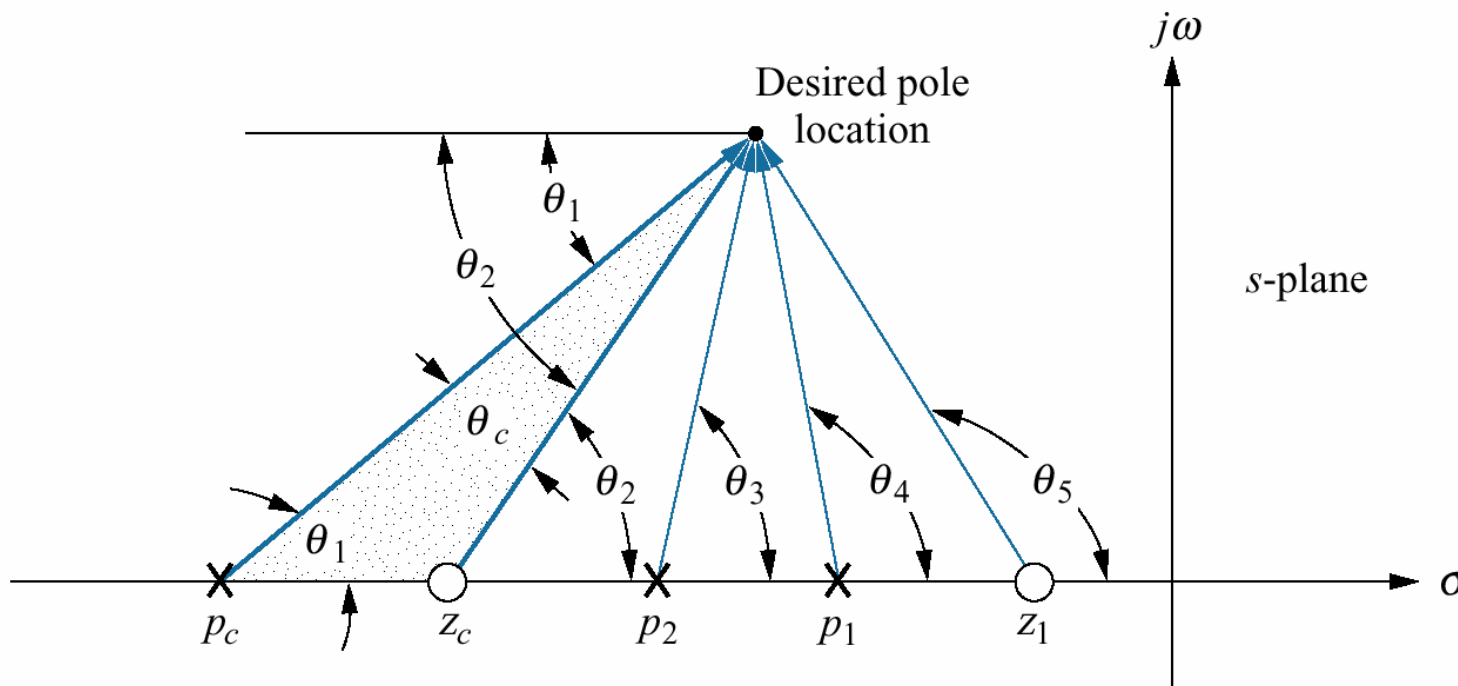
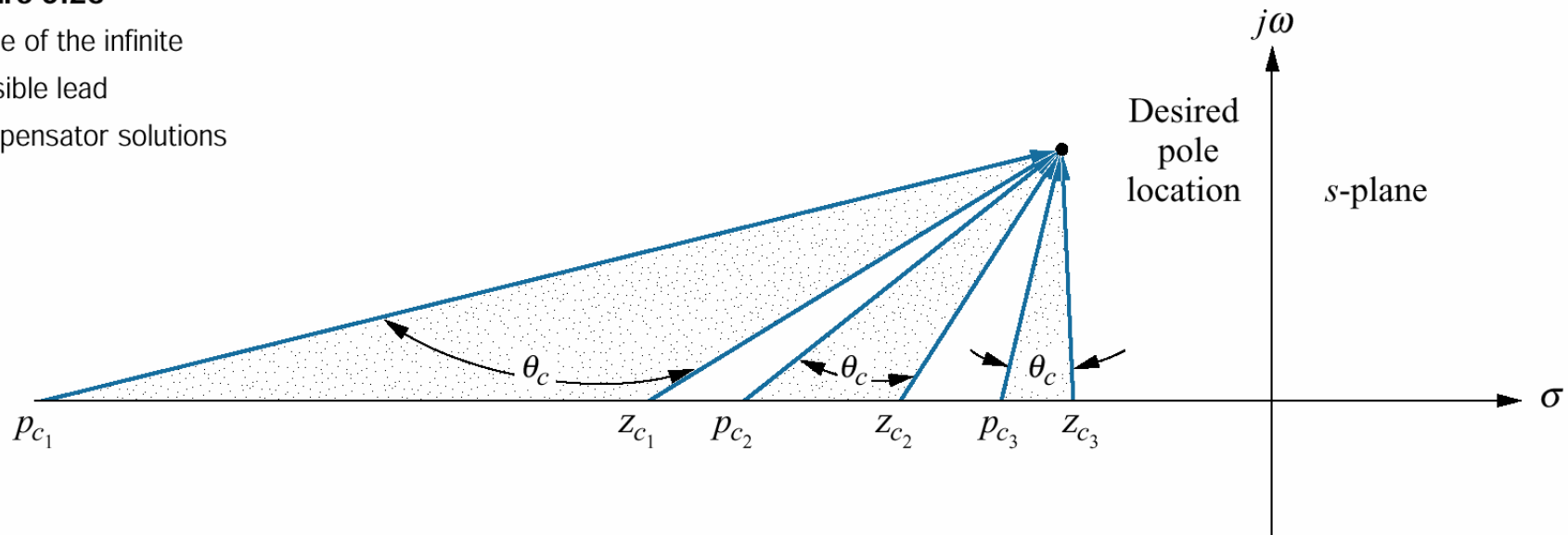

Figure 9.24
Geometry of lead
compensation

Now visualize this ray rotating about the desired closed-loop pole location and intersecting the real axis at the compensator pole and zero, as illustrated in figure below.

Figure 9.25

Three of the infinite possible lead compensator solutions



We realize that an infinite number of lead compensators could be used to meet the transient response requirement. For design, we arbitrarily select either a lead compensator pole or zero and find the angular contribution at the design point of this pole or zero along with system open loop poles and zeros. The difference between this angle and 180° is the required contribution of the remaining compensator pole or zero.

Different examples exist in text book.

Improving Steady-State Error and Transient Response

The design can use either active or passive compensators, as previously described. If we design an active PD controller followed by an active PI controller, the resulting compensator is called a proportional-plus-integral-plus-derivative (PID) controller. If we first design a passive lead compensator and then design a passive lag compensator, the resulting compensator is called a lag-lead compensator.

PID Controller Design : A PID controller is shown in figure below. Its transfer function is

$$G_c(s) = K_1 + \frac{K_2}{s} + K_3s = \frac{K_1s + K_2 + K_2s^2}{s} = \frac{K_3 \left(s^2 + \frac{K_1}{K_3}s + \frac{K_2}{K_3} \right)}{s}$$

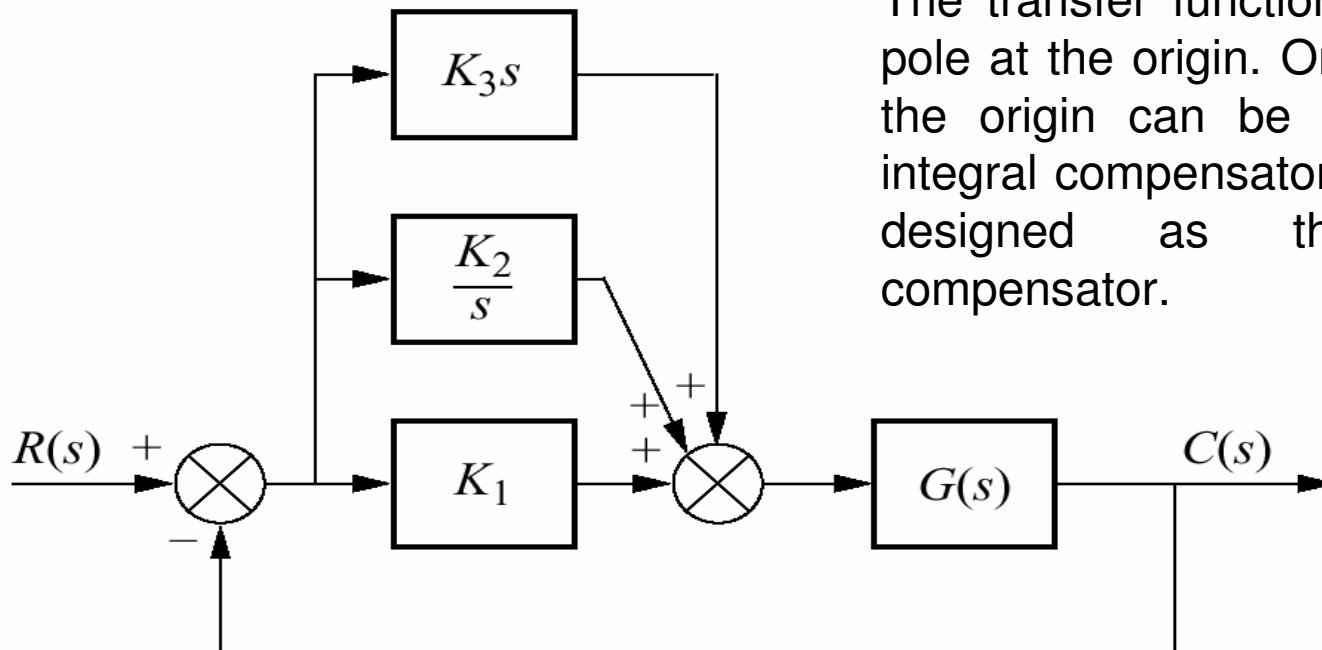

The transfer function has two zeros and a pole at the origin. One zero and the pole at the origin can be designed as the ideal integral compensator; the other zero can be designed as the ideal derivative compensator.

Design technique consists of the following steps :

1. Evaluate the performance of the uncompensated system to determine how much improvements in transient response is required.
2. Design the PD controller to meet the transient response specifications. The design includes the zero location and the loop gain.
3. Simulate the system to be sure all requirements have been met.
4. Redesign if the simulation shows that the requirements have not been met.
5. Design PI controller to yield the required steady-state error.
6. Determine the gain K_1 , K_2 , K_3 , the PID parameters.
7. Simulate the system to be sure all requirements have been met.
8. Redesign if the simulation shows that the requirements have not been met

Let us look an example.

Example : Given the system of figure below, design a PID controller so that the system can operate with a peak time that is two-thirds that of the uncompensated system at %20 overshoot and with zero steady-state error for a step input.

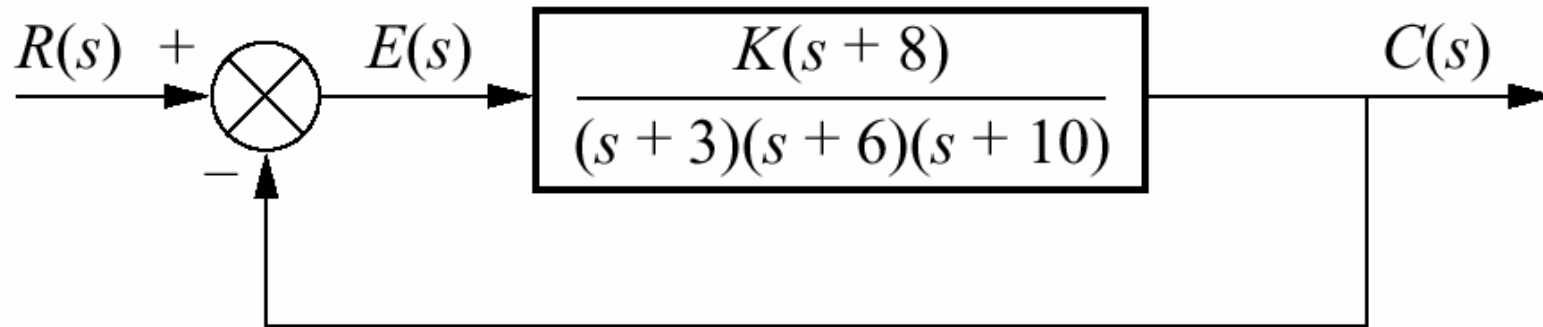

Solution : Step 1 : Let us first evaluate the uncompensated system operating at 20% overshoot. Searching along the 20% overshoot line ($\zeta=0.456$) in root-locus, we find the dominant poles to be $-5.415 \pm j10.57$ with a gain 121.5. A third pole exists at -8.619 . The complete performance of the uncompensated system is shown in the first column of the following table. We estimate that the uncompensated system has a peak time 0.297 second at 20% overshoot(look at the table).

Table 9.5

Predicted characteristics of uncompensated, PD-, and PID- compensated systems

	Uncompensated	PD-compensated	PID-compensated
Plant and compensator	$\frac{K(s+8)}{(s+3)(s+6)(s+10)}$	$\frac{K(s+8)(s+55.92)}{(s+3)(s+6)(s+10)}$	$\frac{K(s+8)(s+55.92)(s+0.5)}{(s+3)(s+6)(s+10)s}$
Dominant poles	$-5.415 \pm j10.57$	$-8.13 \pm j15.87$	$-7.516 \pm j14.67$
K	121.5	5.34	4.6
ζ	0.456	0.456	0.456
ω_n	11.88	17.83	16.49
%OS	20	20	20
T_s	0.739	0.492	0.532
T_p	0.297	0.198	0.214
K_p	5.4	13.27	∞
$e(\infty)$	0.156	0.070	0
Other poles	-8.169	-8.079	-8.099, -0.468
Zeros	-8	-8, -55.92	-8, -55.92, -0.5
Comments	Second-order approx. OK	Second-order approx. OK	Zero at -55.92 and -0.5 not canceled

Step 2 : To compensate the system reduce the peak time to two-thirds of that of the uncompensated system, we must first find compensated system's dominant pole location. The imaginary part of the compensated dominant pole is

$$\omega_d = \frac{\pi}{T_p} = \frac{\pi}{(2/3)(0.297)} = 15.87$$

Thus the real part of the compensated dominant pole is $\sigma = \frac{\omega_d}{\tan 117.13^\circ} = -8.13$

Next we design the compensator. Using the geometry shown in figure,

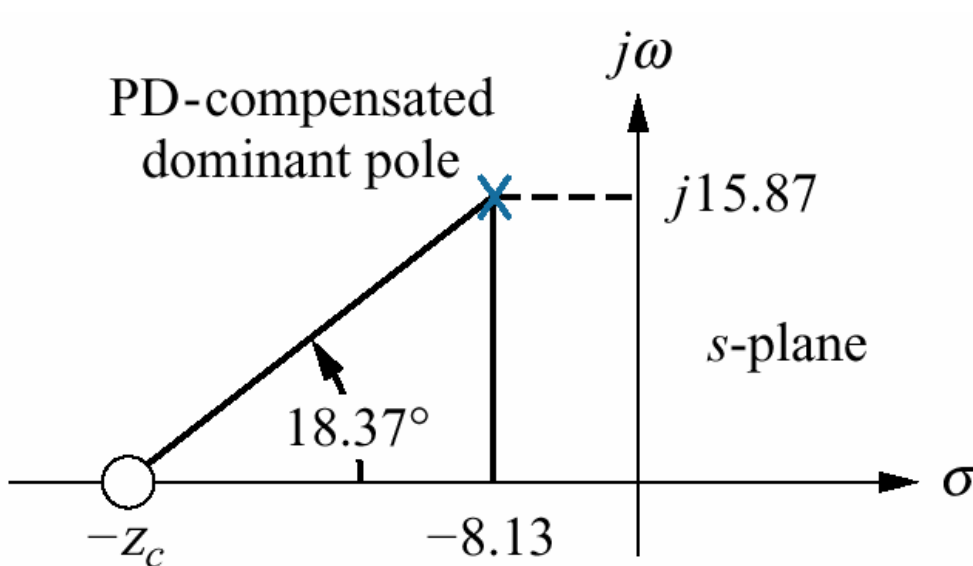

$$\frac{15.87}{z_c - 8.13} = \tan 18.37^\circ$$

then $z_c = 55.92$

Thus, the PD controller is

$$G_{PD} = (s + 55.92)$$

X = Closed-loop pole

Note: This figure is not drawn to scale.

Step 3 and 4 : We simulate the compensated system, as shown in figure below. We see the reduction in peak time and the improvement in steady-state error over the uncompensated system.

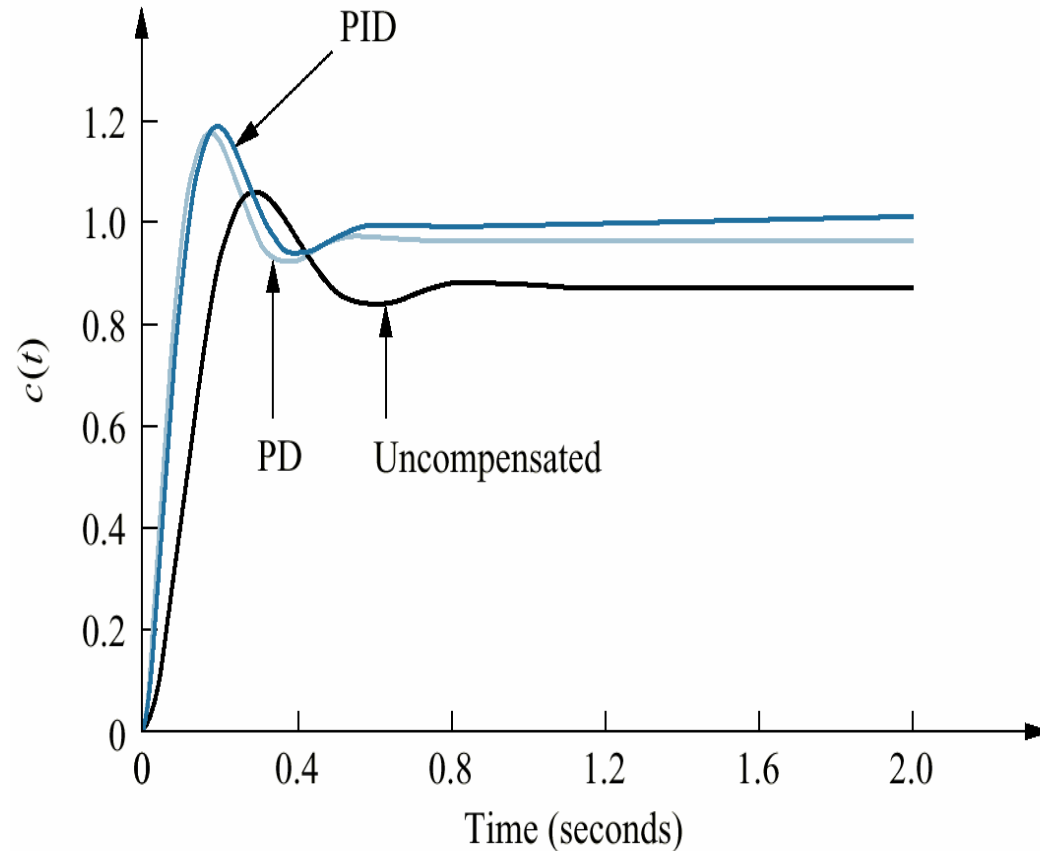
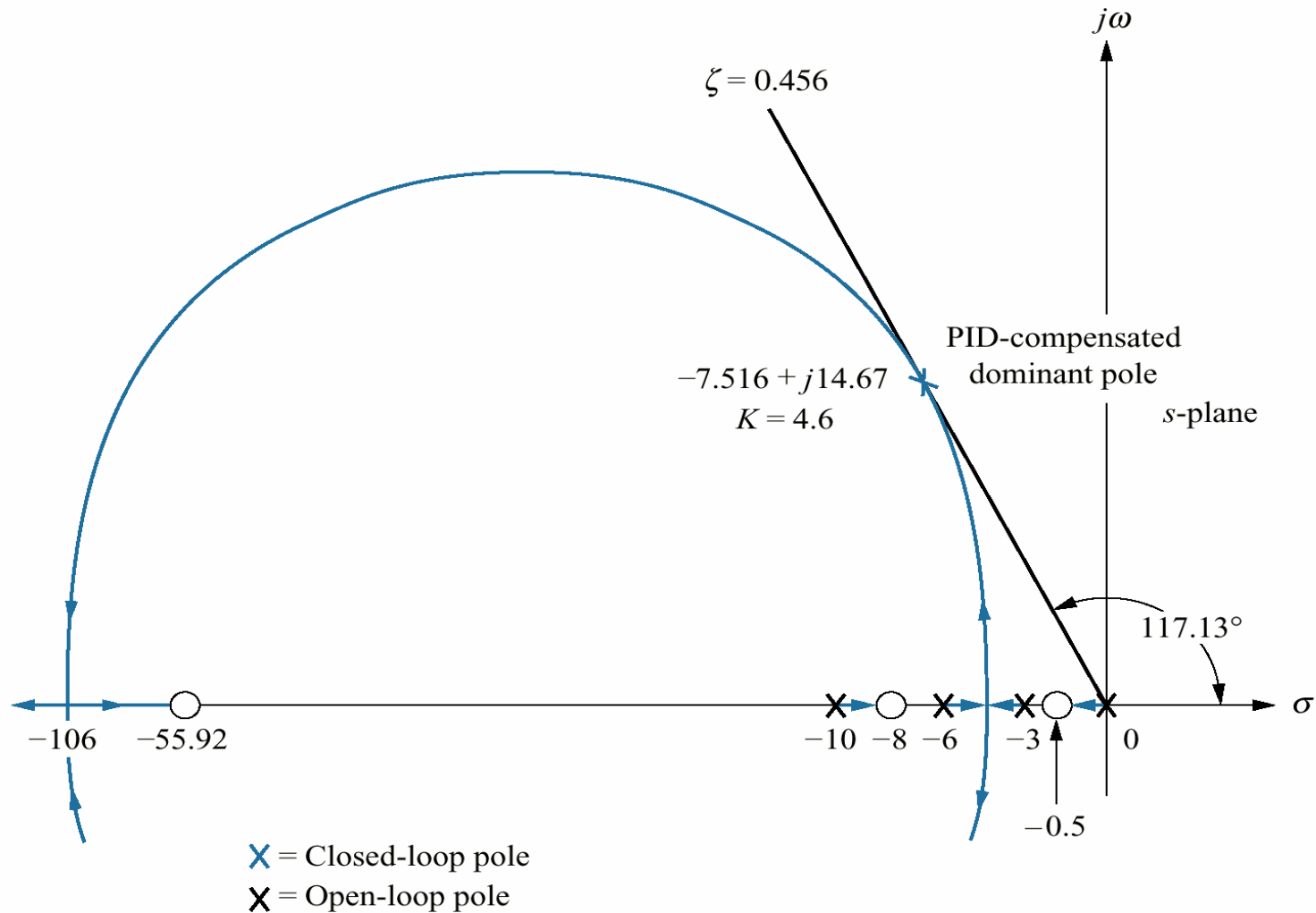

Figure 9.35
Step responses for
uncompensated,
PD-compensated, and
PID-compensated
systems

Step 5 : Choosing the ideal integral compensator to be $G_{PI}(s) = \frac{s + 0.5}{s}$, we sketch the root locus for PID-compensated system, as shown in figure. Searching 0.456 damping ratio line, we find the dominant, second order poles to be $-7.516 \pm j14.67$, with an associated gain of 4.6 .



Note: This figure is not drawn to scale.

Step 6 : Now we determine the gains K_1 , K_2 , K_3 . We have found G_{PD} and G_{PI} . Thus, the product of the gain and the PID controller is

$$G_{PID}(s) = \frac{K(s + 55.92)(s + 0.5)}{s} = \frac{4.6(s + 55.92)(s + 0.5)}{s}$$

$$= \frac{4.6(s^2 + 56.42s + 27.96)}{s}$$

Matching this equation and the transfer function of PID controller we have learned before which is

$$G_c(s) = K_1 + \frac{K_2}{s} + K_3s = \frac{K_1s + K_2 + K_3s^2}{s} = \frac{K_3 \left(s^2 + \frac{K_1}{K_3}s + \frac{K_2}{K_3} \right)}{s}$$

We obtain $K_1=259.5$, $K_2=128.6$ and $K_3=4.6$

Step 7 and 8 : The following figure summarize our design.

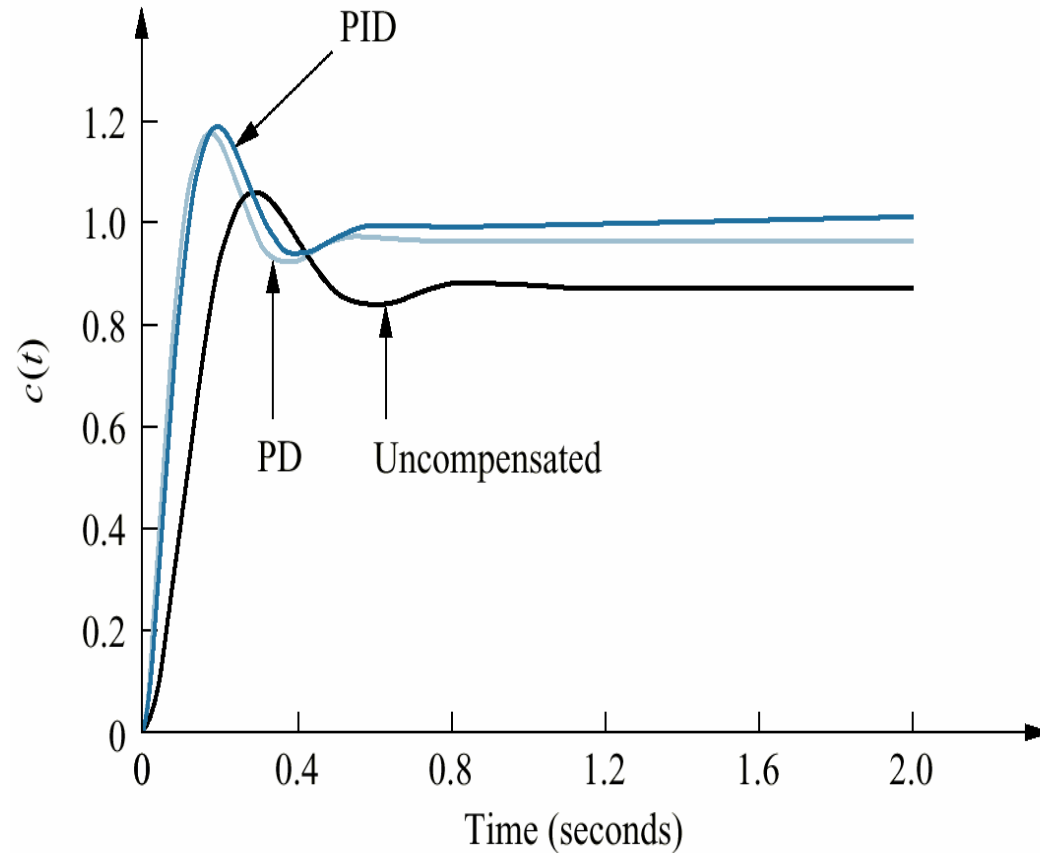

Figure 9.35
Step responses for un-compensated, PD-compensated, and PID-compensated systems

All requirements have been met

Lag-Lead Compensator Design : Another approach to improve steady state error and transient response is lead-lag compensator design. We first design the lead compensator to improve the transient response. Finally we design the lag compensator to meet the steady-state error requirement. The following steps summarize the design procedure :

1. Evaluate the performance of the uncompensated system to determine how much improvements in transient response is required.
2. Design the lead controller to meet the transient response specifications. The design includes the zero location, pole location and the loop gain.
3. Simulate the system to be sure all requirements have been met.
4. Redesign if the simulation shows that the requirements have not been met.
5. Evaluate the steady-state error performance for the lead compensated system to determine how much more improvement in steady-state error is required.
6. Design the lag compensator to yield the required steady-state error.
7. Simulate the system to be sure all requirements have been met.
8. Redesign if the simulation shows that the requirements have not been met

Example : Design a lag-lead compensator for the system of following figure. So that the system will operate with 20% overshoot and a twofold reduction in settling time. Further, the compensated system will exhibit a tenfold improvement in steady-state error for a ramp input.

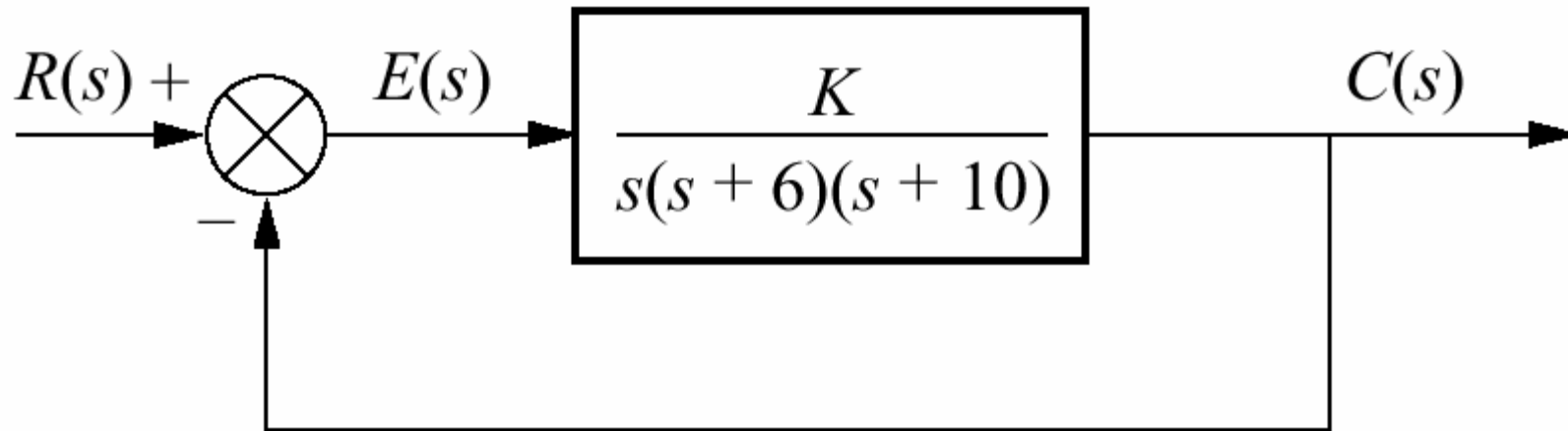

Solution : Step 1: First, we evaluate the performance of uncompensated system. Searching along the 20% overshoot line ($\zeta=0.456$) in the root locus of system, we find the dominant poles at $-1.794 \pm j3.501$, with a gain of 192.1. The performance of the uncompensated system is summarized in the following table.

Figure 9.38

Root locus for
uncompensated
system of
Example 9.6

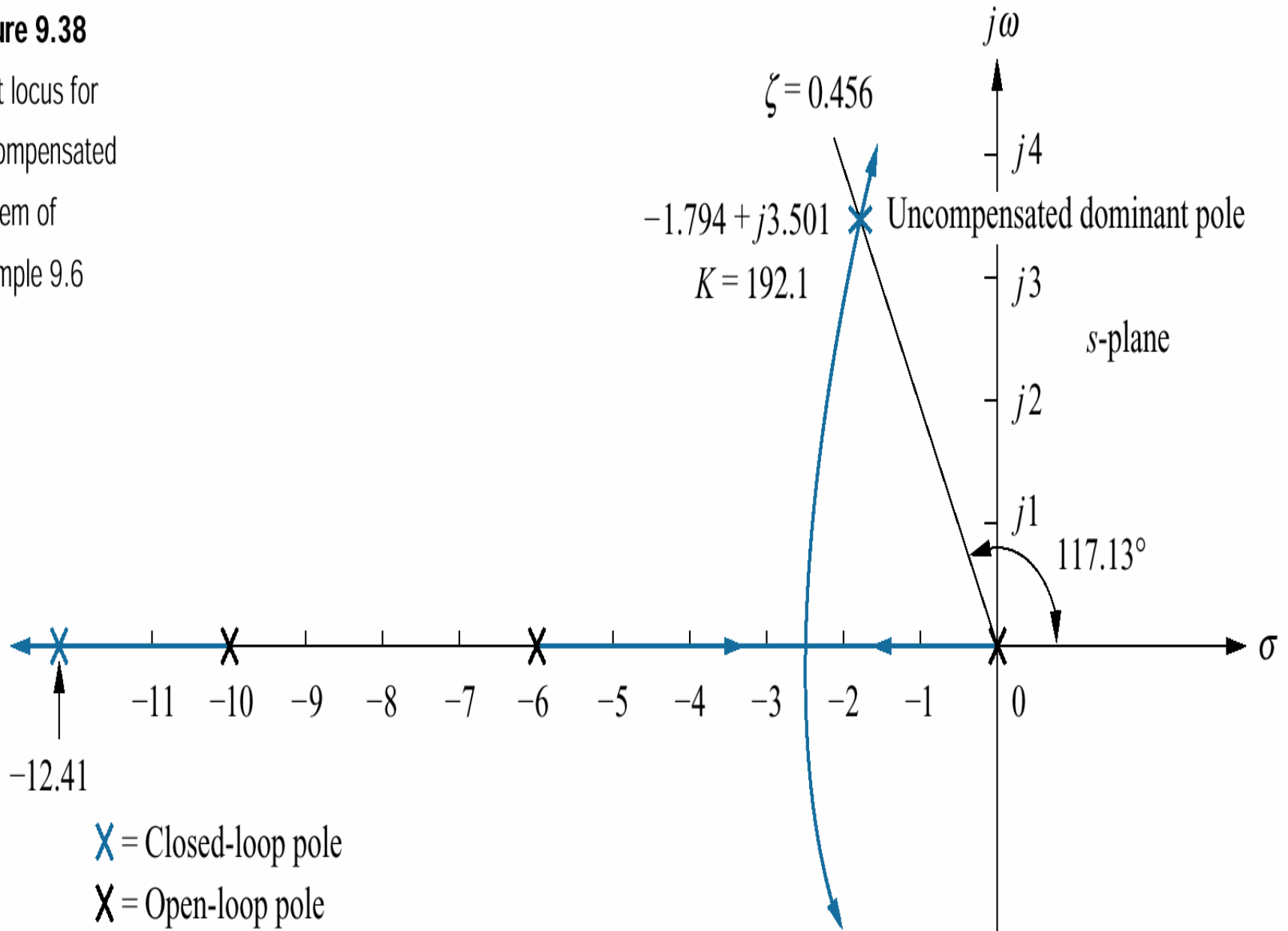

Table

Predicted characteristics of uncompensated, lead-compensated, and lag-lead-compensated systems of Example

	Uncompensated	Lead-compensated	Lag-lead-compensated
Plant and compensator	$\frac{K}{s(s+6)(s+10)}$	$\frac{K}{s(s+10)(s+29.1)}$	$\frac{K(s+0.04713)}{s(s+10)(s+29.1)(s+0.01)}$
Dominant poles	$-1.794 \pm j3.501$	$-3.588 \pm j7.003$	$-3.574 \pm j6.976$
K	192.1	1977	1971
ζ	0.456	0.456	0.456
ω_n	3.934	7.869	7.838
%OS	20	20	20
T_s	2.230	1.115	1.119
T_p	0.897	0.449	0.450
K_v	3.202	6.794	31.92
$e(\infty)$	0.312	0.147	0.0313
Third pole	-12.41	-31.92	-31.91, -0.0474
Zero	None	None	-0.04713
Comments	Second-order approx. OK	Second-order approx. OK	Second-order approx. OK

Step2 : Next we design a lead compensator by selecting the location of uncompensated system's dominant poles. In order to realize a twofold reduction of settling time, the real part of the dominant pole must be increased by a factor of 2, since the settling time is inversely proportional to the real part. Thus, $-\zeta\omega_n = -2(1.794) = -3.588$. the imaginary part of the design point is $\omega_d = \zeta\omega_n \tan 117.13^\circ = 7.003$. Now we design the lead compensator. For this example we select the location of the compensator zero coincident with the the open loop pole at -6. This choice will eliminate a zero and leave the lead compensated system with three poles, the same number that the uncompensated system has. We complete the design by by finding the location of the compensator pole. Using the root locus program, sum the angles to the design point from the uncompensated system's poles and zeros and the compensator zero and get -164.65° . The difference between 180° and this quantity is the angular contribution required from the compensator pole, or -15.35° . Using the geometry shown in figure,

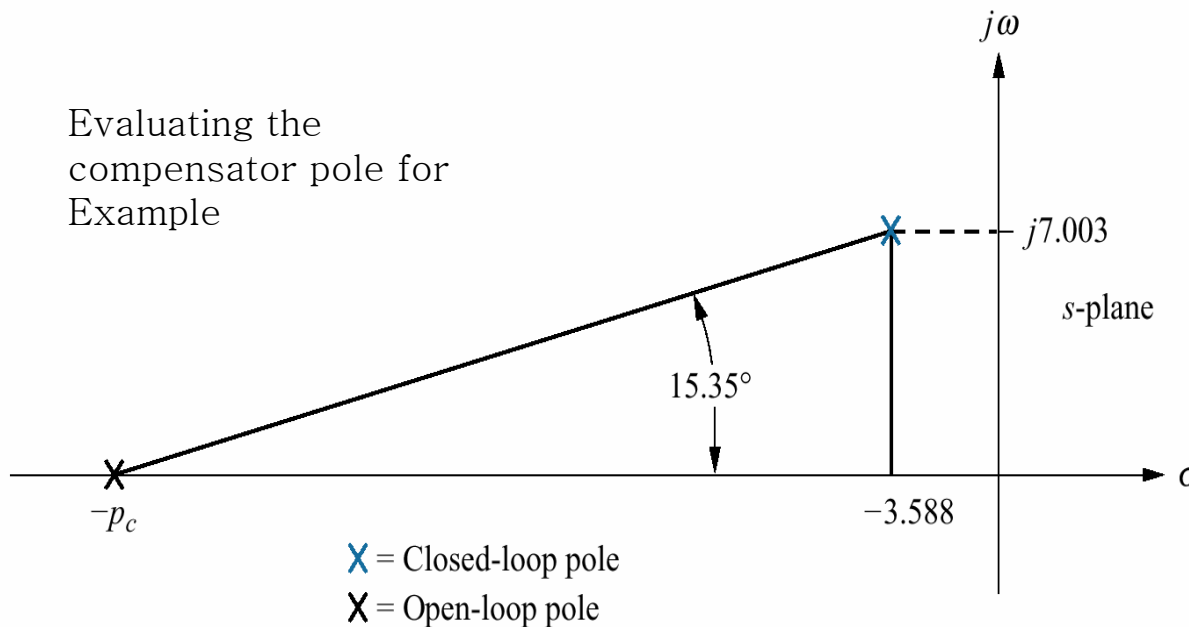

$$\frac{7.003}{p_c - 3.588} = \tan 15.35^\circ$$

from which the location of compensator pole p_c is found to be -29.1. The complete root locus for the lead compensation system is sketched in the following figure. The gain setting at the design point is found to be 1977.

Figure 9.40

Root locus for lead-compensated system of Example 9.6

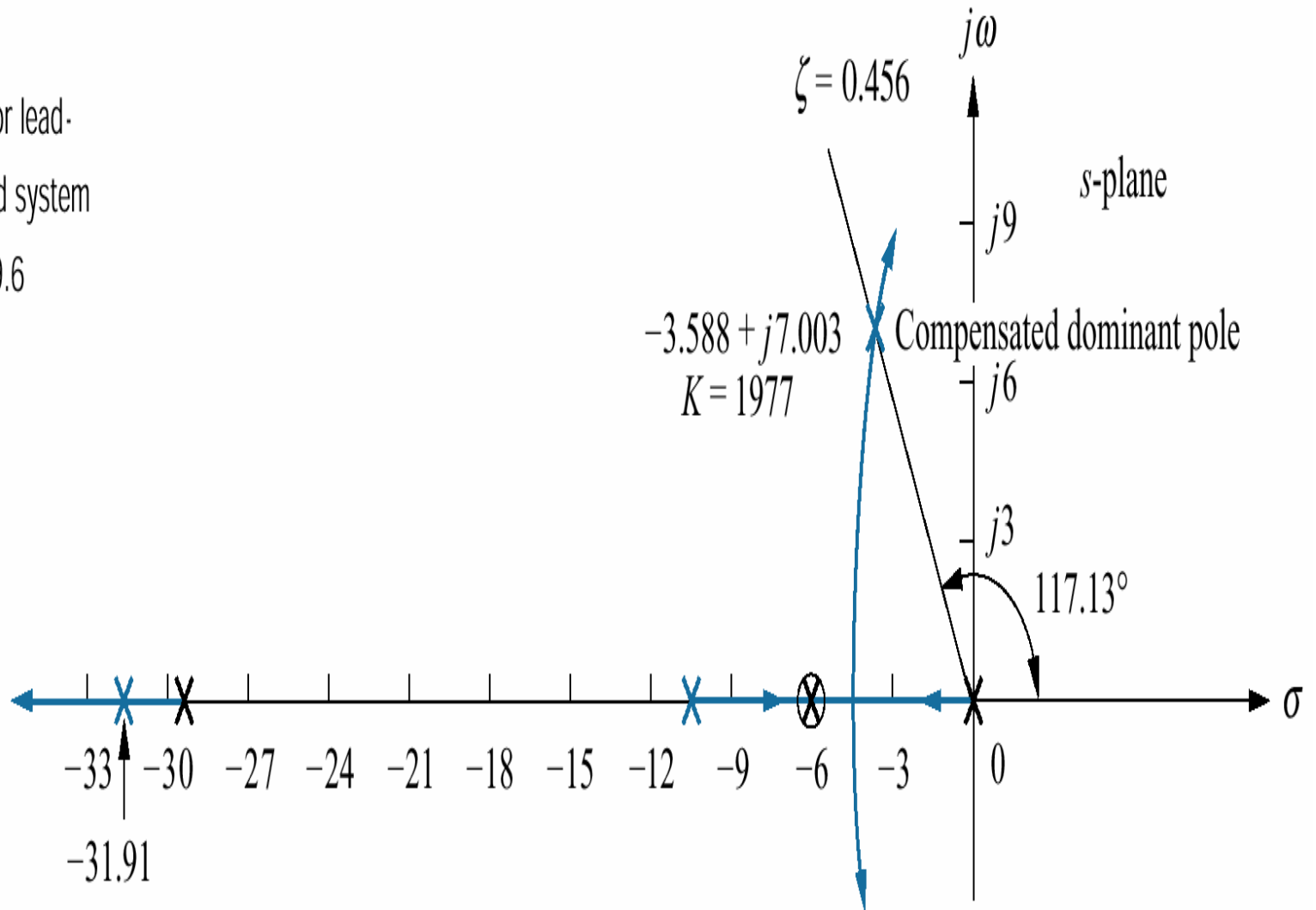

\times = Closed-loop pole

\otimes = Open-loop pole

Step3 and 4 : Check the design with a simulation. The result for the lead compensated system is shown in figure and is satisfactory.

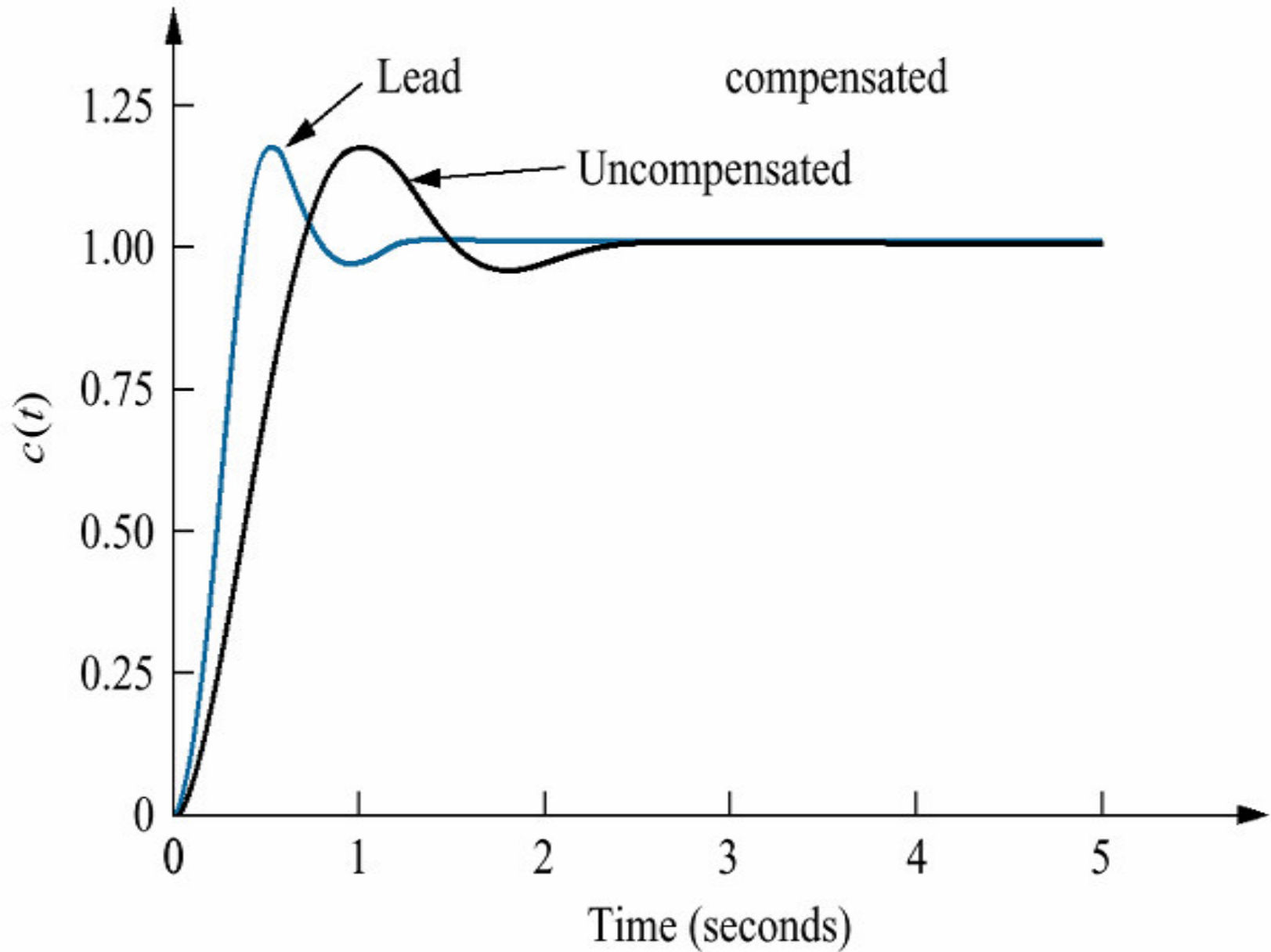

Step5 : Continue by designing the lag compensator to improve the steady-state error. Since the uncompensated system open loop transfer function is

$$G_s = \frac{1921}{s(s+6)(s+10)}$$

The static error constant K_v which is inversely proportional to the steady state error is 3.201. Since the open loop transfer function of the lead compensated system is

$$G_s = \frac{1977}{s(s+10)(s+29.1)}$$

The static error constant is 6.794. Thus, the addition of lead compensation has improved the steady state error by factor of 2.122. since the requirements of the problem specified a tenfold improvement, the lag compensator must be designed to improve the steady-state error by a factor of 4.713 ($10/2.122=4.713$) over the lead compensated system .

Step 6 : We arbitrarily choose the lag compensator pole at 0.01, which then places the lag compensator zero at 0.04713, yielding

$$G_{lag}(s) = \frac{(s+0.04713)}{(s+0.01)}$$

As the lag compensator. The lag-lead compensated system's open loop transfer function

$$G_{LLC} = \frac{K(s+0.04713)}{s(s+10)(s+29.1)(s+0.01)}$$

where the uncompensated system pole at -6 canceled the lead compensator zero at -6.

By drawing the complete root locus for the lag-lead compensated system and by searching along the 0.456 damping ratio line, we find the dominant, the closed loop poles to be at $-3.574 \pm j6.976$, with a gain of 1971. the lag-lead compensated root locus is shown in figure.

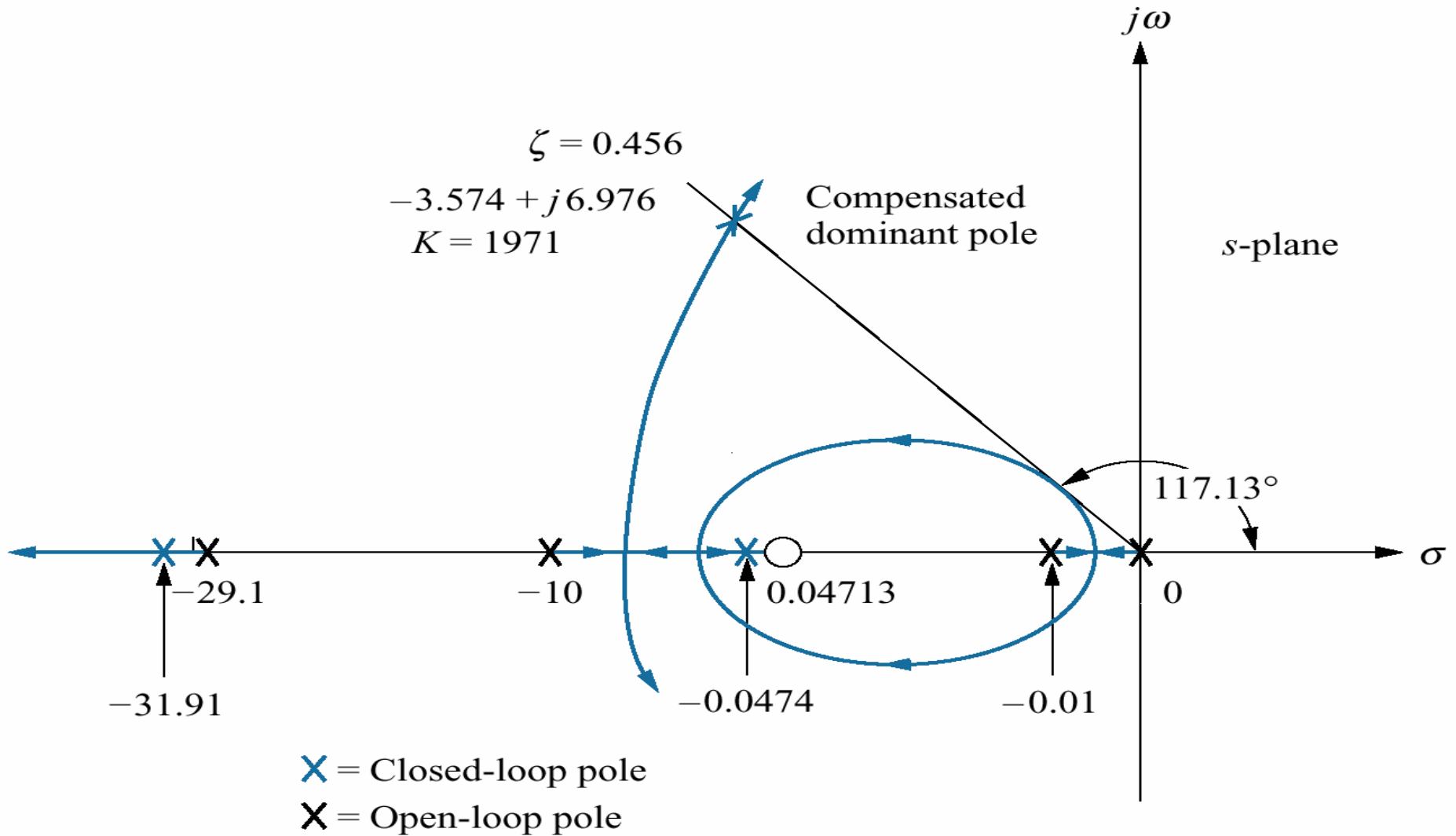

Note: This figure is not drawn to scale.

A summary of our design is shown in following table. Notice that the lag-lead compensation has indeed increased the speed of the system, as witnessed by the settling time or the peak time. The steady-state error for a ramp input has also decreased by about 10 times as $e(\infty)$.

	Uncompensated	Lead-compensated	Lag-lead-compensated
Plant and compensator	$\frac{K}{s(s+6)(s+10)}$	$\frac{K}{s(s+10)(s+29.1)}$	$\frac{K(s+0.04713)}{s(s+10)(s+29.1)(s+0.01)}$
Dominant poles	$-1.794 \pm j3.501$	$-3.588 \pm j7.003$	$-3.574 \pm j6.976$
K	192.1	1977	1971
ζ	0.456	0.456	0.456
ω_n	3.934	7.869	7.838
%OS	20	20	20
T_s	2.230	1.115	1.119
T_p	0.897	0.449	0.450
K_v	3.202	6.794	31.92
$e(\infty)$	0.312	0.147	0.0313
Third pole	-12.41	-31.92	-31.91, -0.0474
Zero	None	None	-0.04713
Comments	Second-order approx. OK	Second-order approx. OK	Second-order approx. OK

Step 7 : The final proof of our designs is shown by the simulation of following figures.

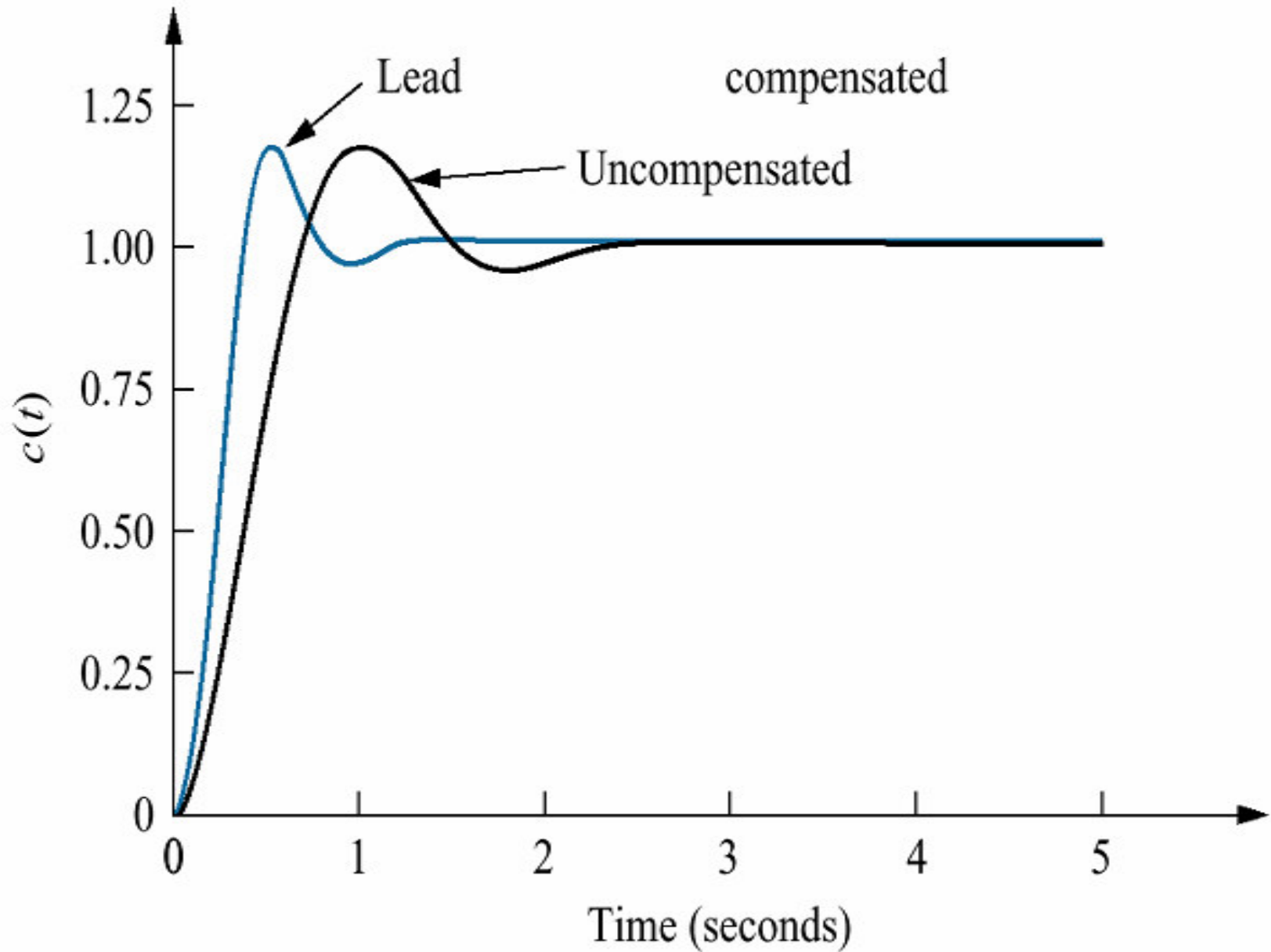

Following tables show the summary of cascade compensators.

Table 9.7 Types of cascade compensators

Function	Compensator	Transfer function	Characteristics
Improve steady-state error	PI	$K \frac{s + z_c}{s}$	<ol style="list-style-type: none"> 1. Increases system type. 2. Error becomes zero. 3. Zero at $-z_c$ is small and negative. 4. Active circuits are required to implement.
Improve steady-state error	Lag	$K \frac{s + z_c}{s + p_c}$	<ol style="list-style-type: none"> 1. Error is improved but not driven to zero. 2. Pole at $-p_c$ is small and negative. 3. Zero at $-z_c$ is close to, and to the left of, the pole at $-p_c$. 4. Active circuits are not required to implement.
Improve transient response	PD	$K(s + z_c)$	<ol style="list-style-type: none"> 1. Zero at $-z_c$ is selected to put design point on root locus. 2. Active circuits are required to implement. 3. Can cause noise and saturation; implement with rate feedback or with a pole (lead).
Improve transient response	Lead	$K \frac{s + z_c}{s + p_c}$	<ol style="list-style-type: none"> 1. Zero at $-z_c$ and pole at $-p_c$ are selected to put design point on root locus. 2. Pole at $-p_c$ is more negative than zero at $-z_c$. 3. Active circuits are not required to implement.

Improve steady-state error and transient response

PID

$$K \frac{(s + z_{\text{lag}})(s + z_{\text{lead}})}{s}$$

1. Lag zero at $-z_{\text{lag}}$ and pole at origin improve steady-state error.
2. Lead zero at $-z_{\text{lead}}$ improves transient response.
3. Lag zero at $-z_{\text{lag}}$ is close to, and to the left of, the origin.
4. Lead zero at $-z_{\text{lead}}$ is selected to put design point on root locus.
5. Active circuits required to implement.
6. Can cause noise and saturation; implement with rate feedback or with an additional pole.

Improve steady-state error and transient response

Lag-lead

$$K \frac{(s + z_{\text{lag}})(s + z_{\text{lead}})}{(s + p_{\text{lag}})(s + p_{\text{lead}})}$$

1. Lag pole at $-p_{\text{lag}}$ and lag zero at $-z_{\text{lag}}$ are used to improve steady-state error.
 2. Lead pole at $-p_{\text{lead}}$ and lead zero at $-z_{\text{lead}}$ are used to improve transient response.
 3. Lag pole at $-p_{\text{lag}}$ is small and negative.
 4. Lag zero at $-z_{\text{lag}}$ is close to, and to the left of, lag pole at $-p_{\text{lag}}$.
 5. Lead zero at $-z_{\text{lead}}$ and lead pole at $-p_{\text{lead}}$ are selected to put design point on root locus.
 6. Lead pole at $-p_{\text{lead}}$ is more negative than lead zero at $-z_{\text{lead}}$.
 7. Active circuits are not required to implement.
-

FEEDBACK COMPENSATION

The design procedures for feedback compensation can be more complicated than for cascade compensation. On the other hand, feedback compensation can yield faster response. A configuration included feedback compensator is shown in following figure. Note that feedback compensator $H_c(s)$ is placed in the minor loop of a feedback control system.

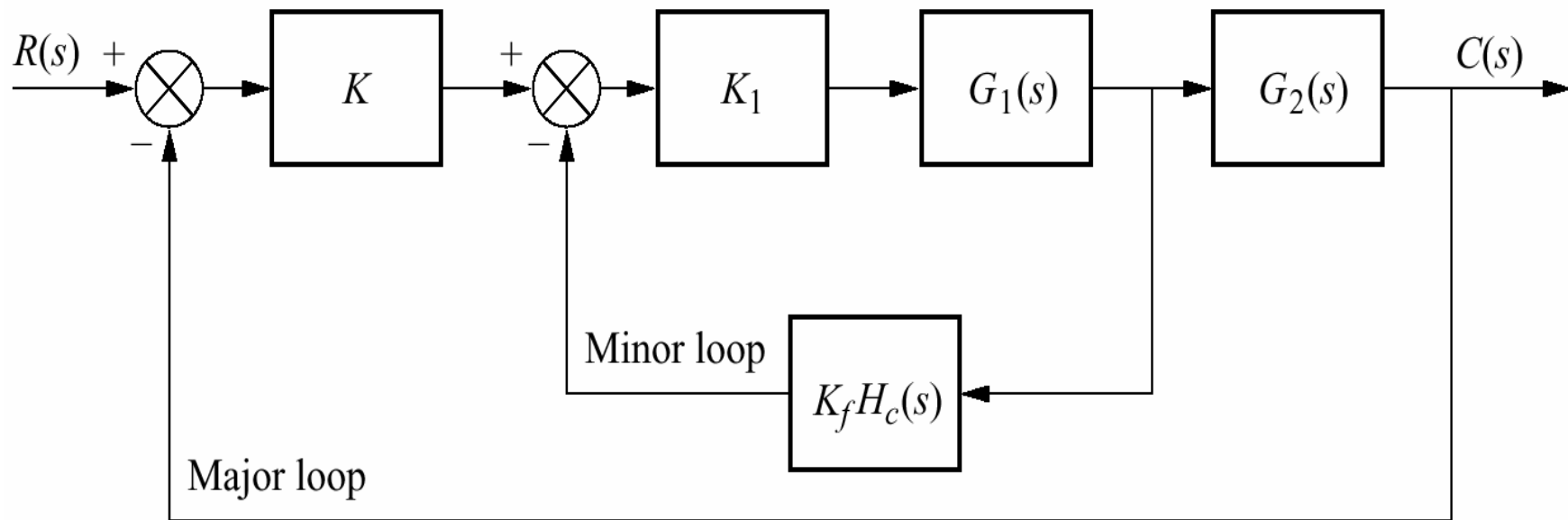

Other configurations arise if we consider K unity, $G_2(s)$ unity, or both unity.

The equivalent block diagram is shown in figure below.

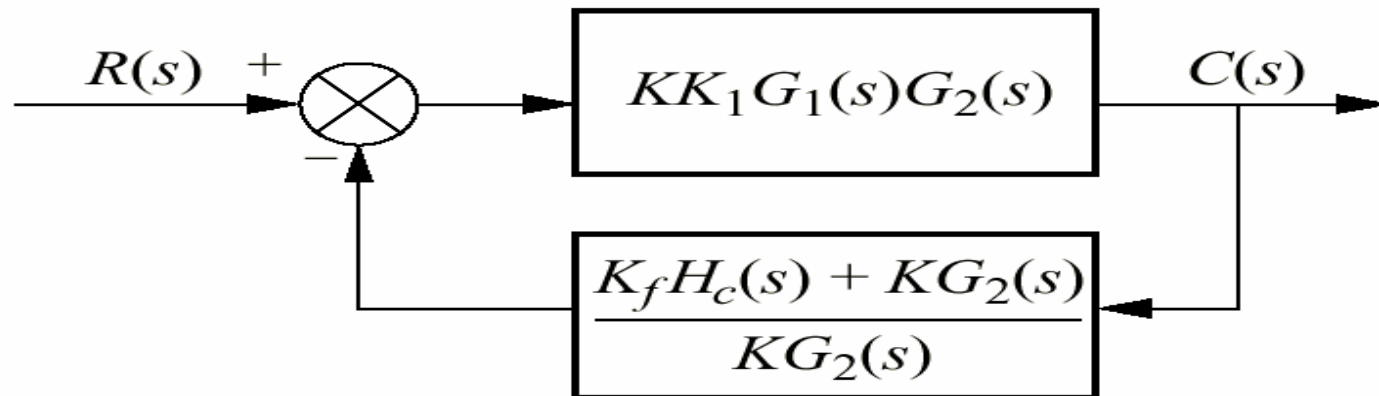

A popular feedback compensator is tachometer as shown in figure below. A tachometer is a voltage generator that yields a voltage output proportional to the input rotational speed.

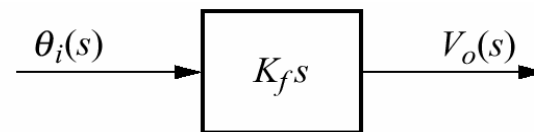

(a)

Figure

- a. Transfer function of a tachometer;
- b. tachometer feedback compensation

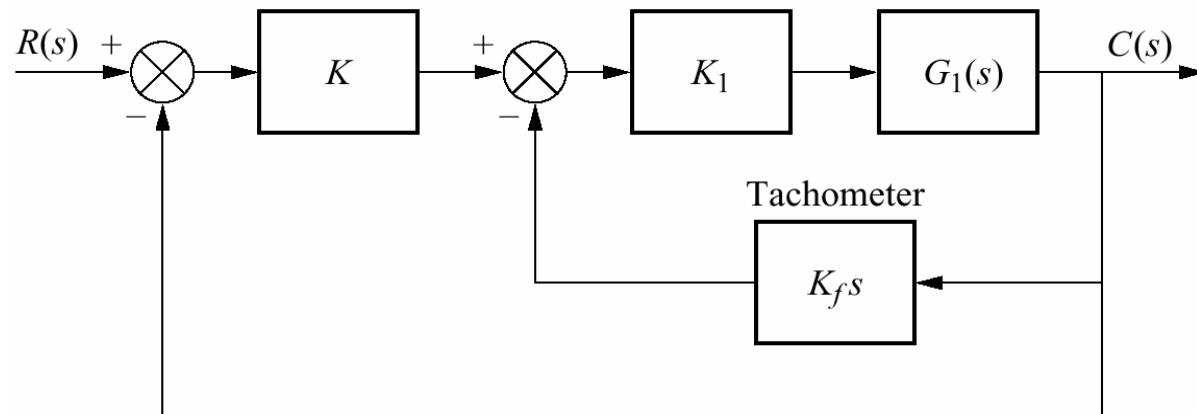

(b)

We now discuss the design procedures. The design of feedback compensation consists of finding the gains, such as K , K_1 and K_f which are seen in the previous block diagram after establishing a dynamic form for H_c . There are two approaches.

Approach 1 : The first approach consists of reducing the first figure to the second one by pushing K to the right past summing junction, pushing $G_2(s)$ to the left past the pickoff point, and then adding the two feedback paths.

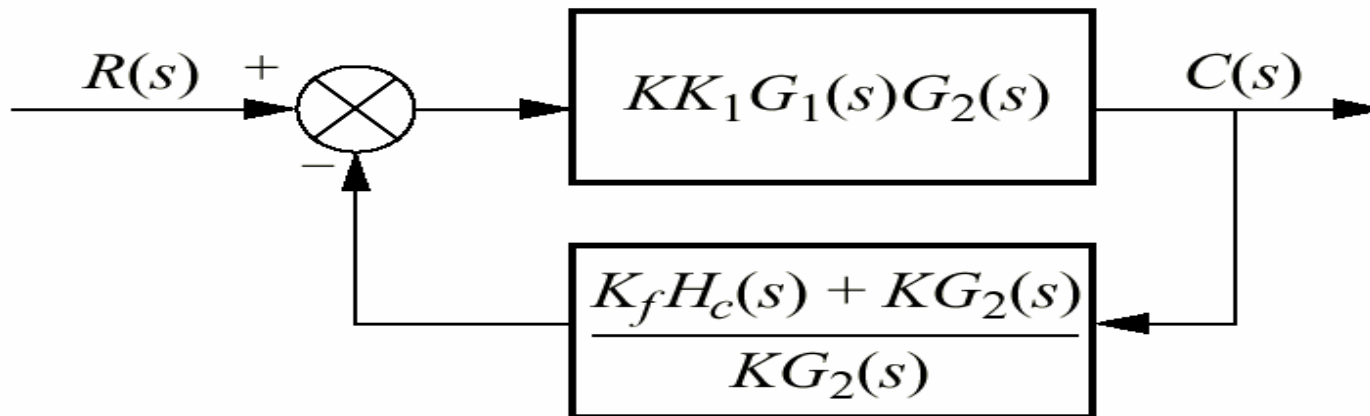
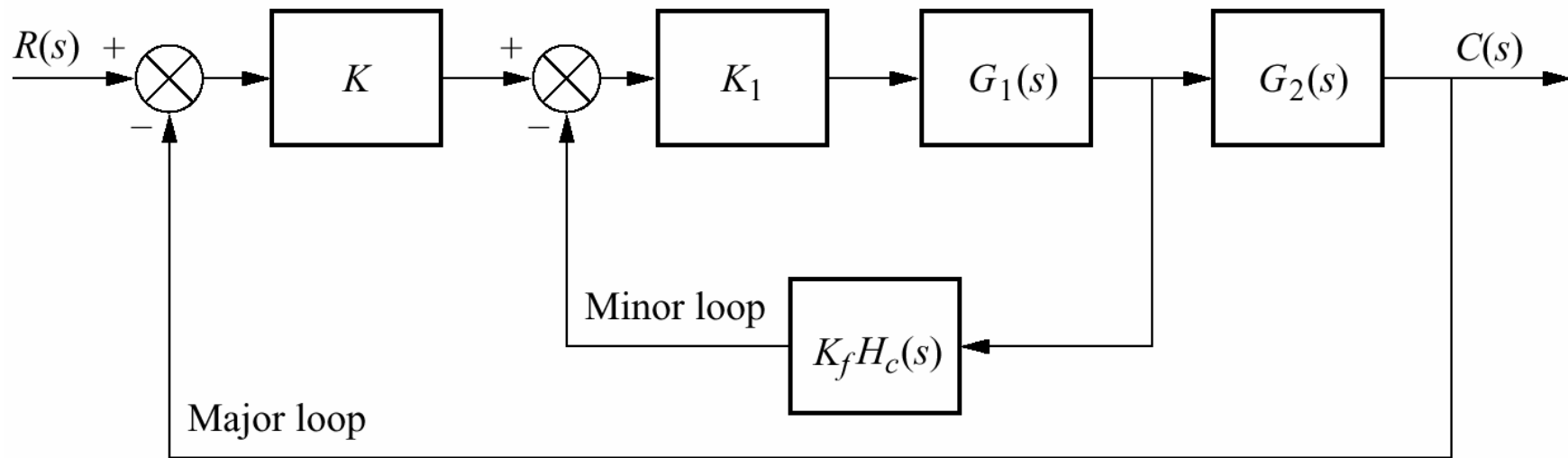

Following figure shows that the loop gain, $G(s)H(s)$, is

$$G(s)H(s) = K_1 G_1(s) [K_f H_c(s) + K G_2(s)]$$

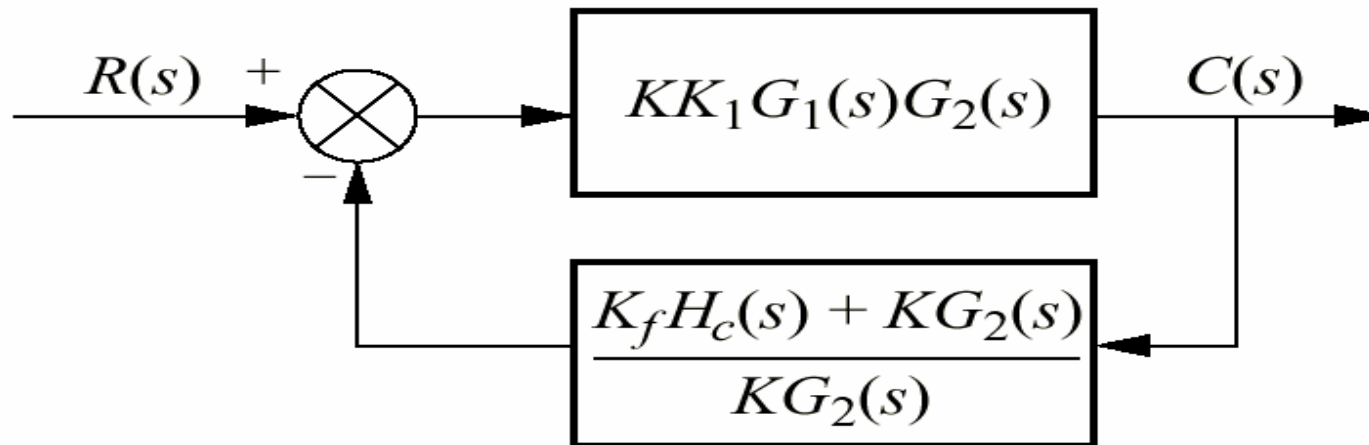

For example, if $G_2(s)=1$ and minor loop feedback, $K_f H_c(s)$, is a rate sensor, $K_f H_c(s)=K_f s$, then using the formulation above the loop gain is

$$G(s)H(s) = K_f K_1 G_1(s) \left(s + \frac{K}{K_f} \right)$$

Thus a zero at $-K/K_f$ is added to the existing open loop poles and zeros. This zero reshapes the root locus so that it goes through the desired design point. A final adjustment of the gain, K_1 , yields the desired response. Again, you should verify that this zero is not a closed loop zero. Let us look at a numerical example.

Example : Given the system of figure(a), design rate feedback compensation as shown in figure(b) to reduce the settling time by a factor of 4 while continuing to operate the system with 20% overshoot.

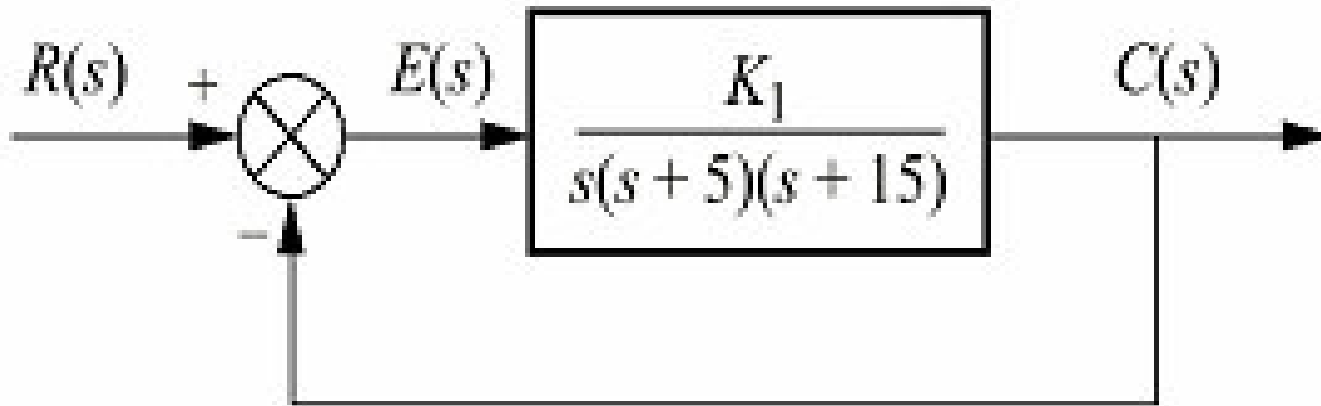

(a)

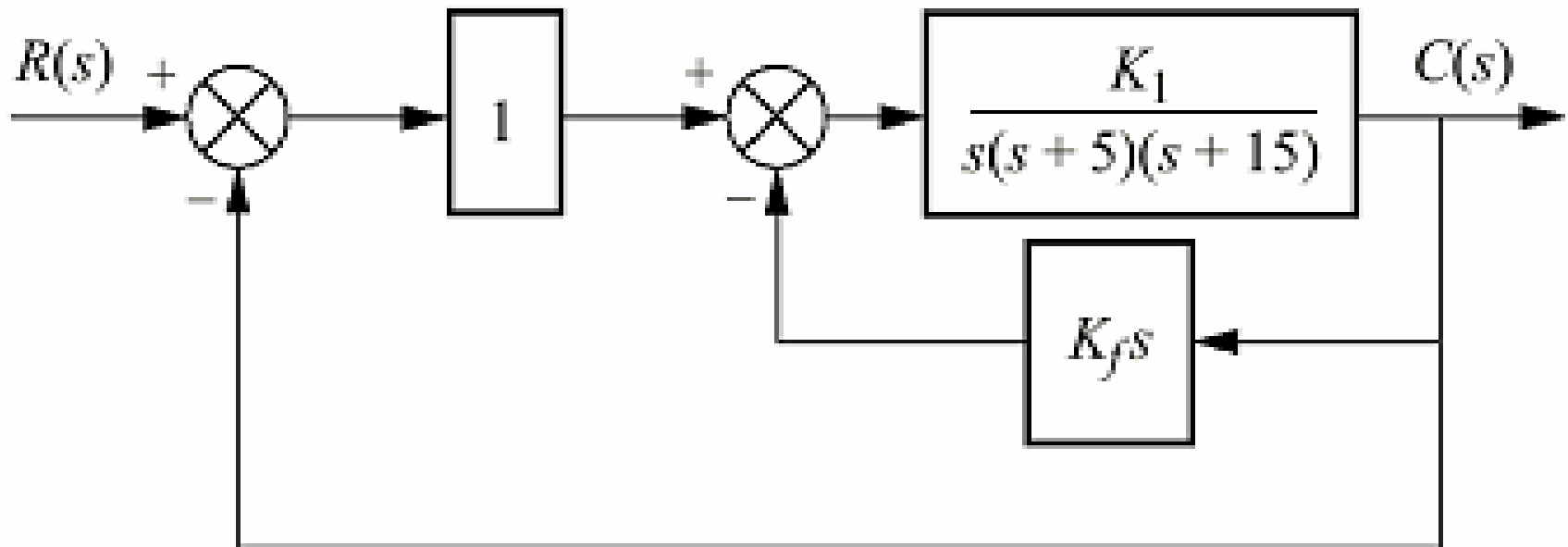

(b)

Solution : First design a PD compensator. For the uncompensated system search along 20% overshoot line ($\zeta=0.456$) and find the dominant poles are that $-1.809 \pm j3.531$, (you can find this values by sketching the root locus). The settling time is 2.21 second and must be reduced by a factor of 4 to 0.55 second. Next determine the location of the dominant poles for the compensated system. To achieve a fourfold decrease in the settling time, the real part of the pole must be increased by a factor of 4. Thus the compensated pole has a real part of $4 \cdot (-1.809) = -7.236$. The imaginary part is then

$$\omega_d = -7.236 \tan 117.13^\circ = 14.12$$

where 117.13 is the angle of the 20% overshoot line. Using the compensated position of $-7.236 \pm j14.12$, we sum the angles from the compensated system poles and obtain -277.33° . This angle requires a compensator zero contribution of $+97.33^\circ$ to yield 180° at the design point. The geometry is shown in following figure leads to the calculation of the compensator zero location. Hence

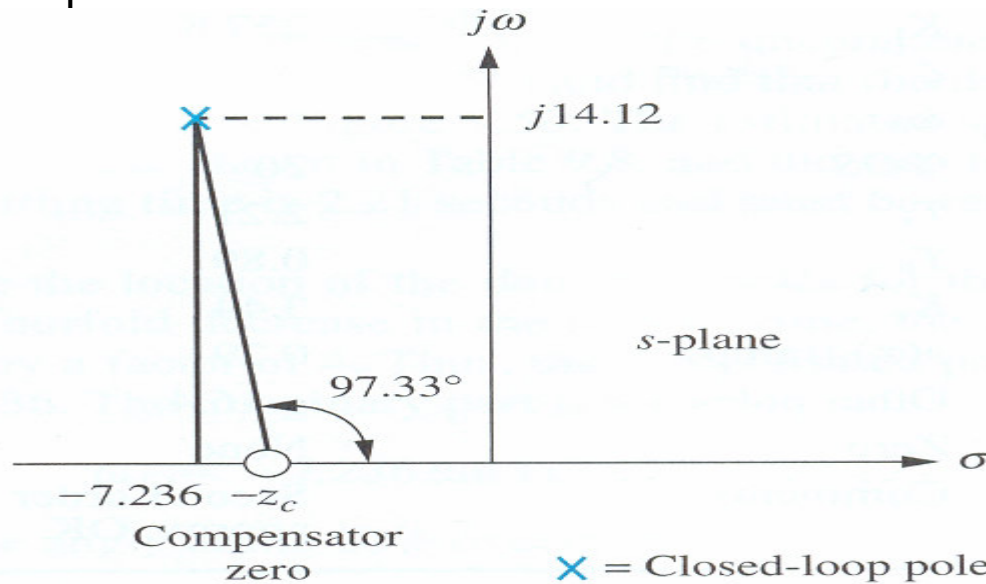

$$\frac{14.12}{7.236 - z_c} = \tan(180^\circ - 97.33^\circ)$$

from which $z_c = 5.42$

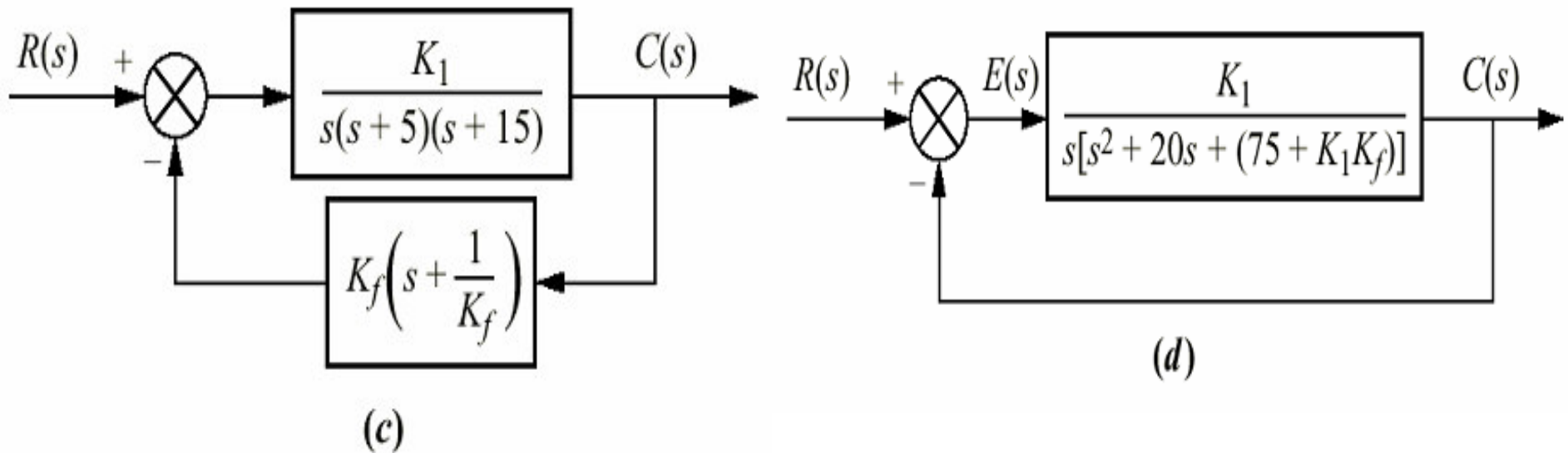

The gain at the design point, which is K_1K_f from figure(c), is found to be 256.7 . Since K_f is the reciprocal of the compensator zero, $K_f=0.185$. Thus $K_1=1388$. In order to evaluate the steady-state error characteristic, K_v is found from figure(d) to be

$$K_v = \frac{K_1}{75 + K_1K_f} = 4.18$$

The closed loop transfer function is

$$T(s) = \frac{G(s)}{1 + G(s)H(s)} = \frac{K_1}{s^3 + 20s^2 + (75 + K_1K_f)s + K_1}$$

The result of simulation is shown in following figure. Figure shows the design specifications are met.

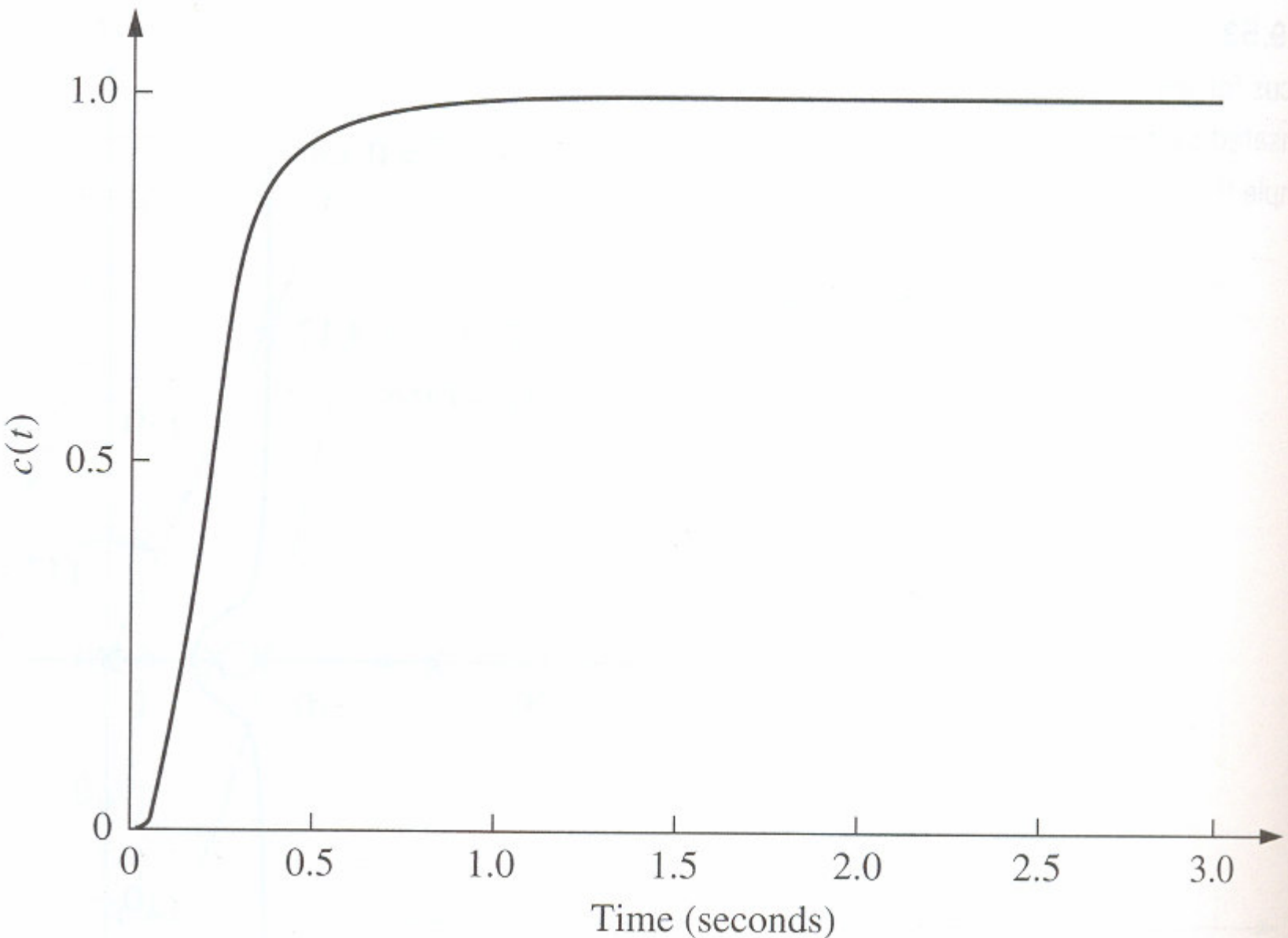

Approach 2 : The second approach allows us to use feedback compensation to design a minor loop's transient response separately from the closed loop system response. We will see that the minor loop of the figure basically represents a forward path transfer function whose poles can be adjusted with the minor loop gain. These poles then become the open loop poles for the entire control system. In other words, rather than reshaping the root locus with additional poles or zeros, as in cascade compensation, we can actually change the plant's poles through a gain adjustment. Finally, the closed loop poles are set by the loop gain, as in cascade compensation

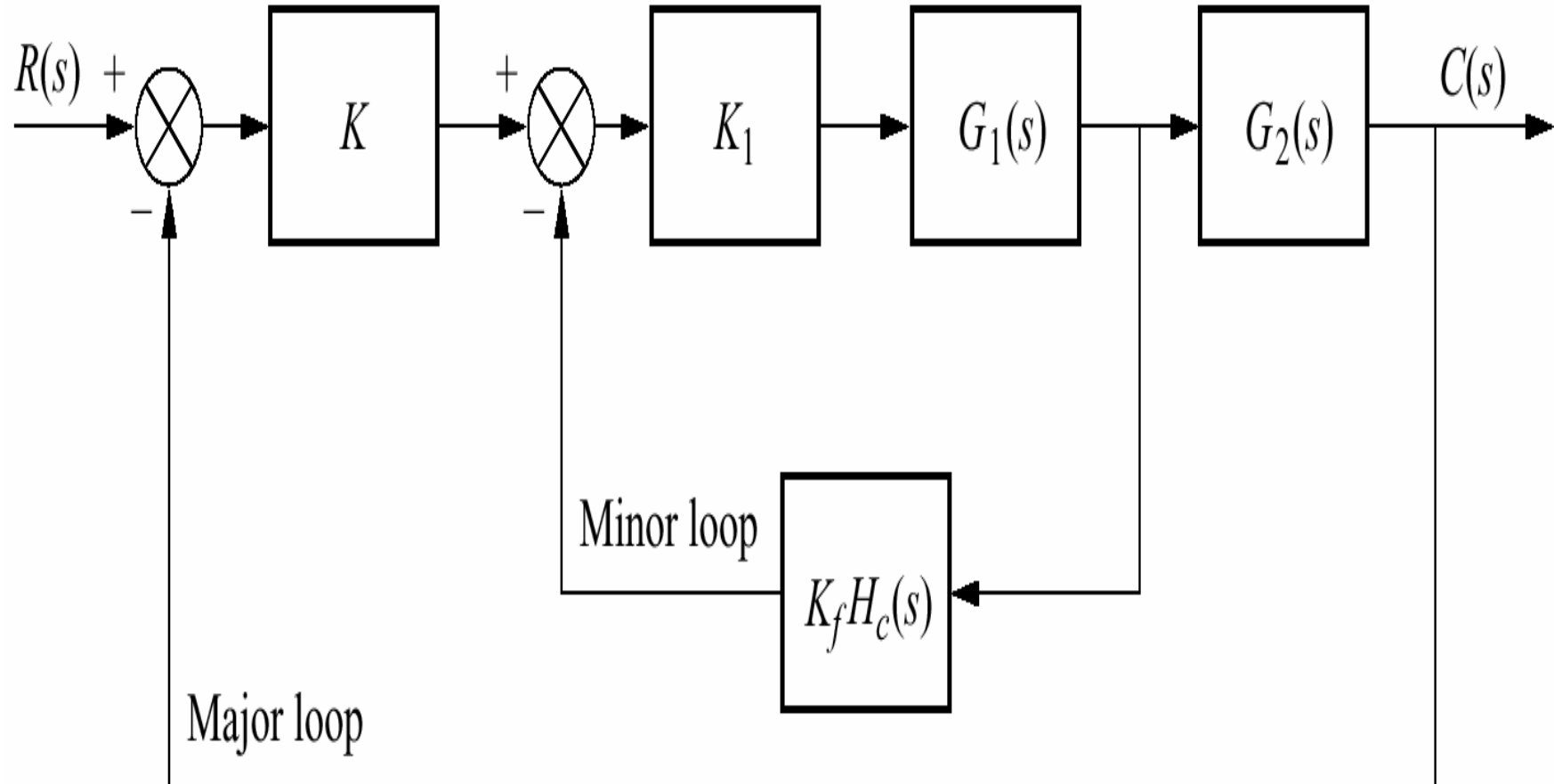

Example : For the system of following figure(a), design a minor loop feedback compensation, as shown in figure (b), to yield a damping ratio of 0.8 for the minor loop and a damping ratio of 0.6 for the closed loop system.

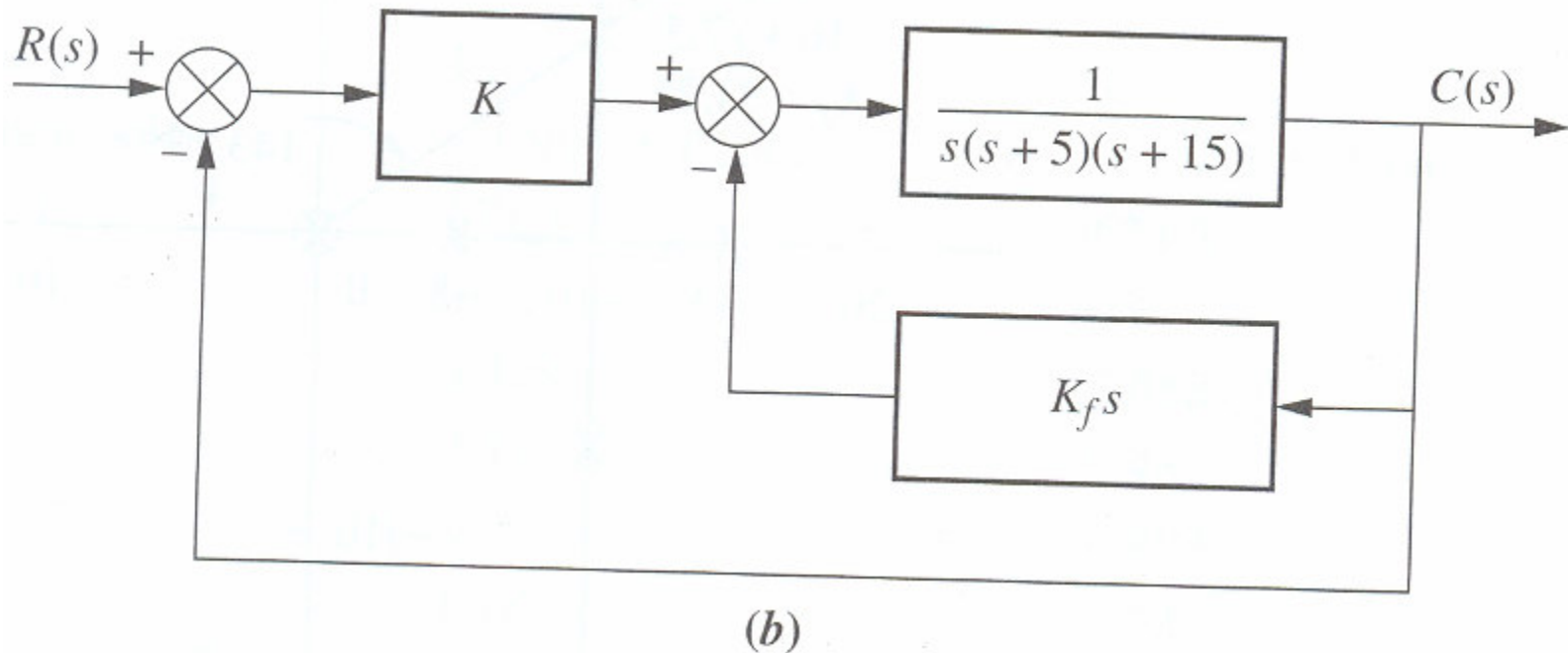
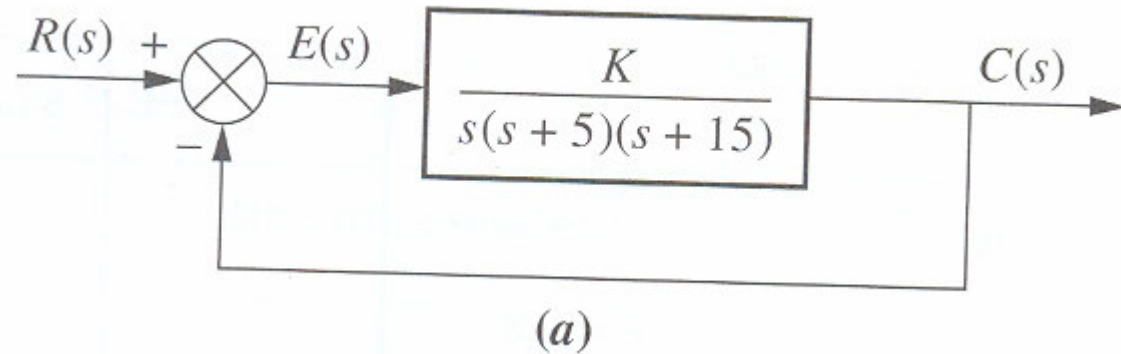

Solution : The minor loop is defined as the loop containing the plant, $1/[s(s+5)(s+15)]$, and the feedback compensator, $K_f s$. The value of K_f will be adjusted to set the location of the minor loop poles, and then K will be adjusted to yield the desired closed loop response. The transfer function of the minor loop, $G_{ML}(s)$, is

$$G_{ML}(s) = \frac{1}{s[s^2 + 20s + (75 + K_f)]}$$

The poles of G_{ML} can be found analytically or via the root locus. If the root locus for the minor loop, where $K_f s/[s(s+5)(s+15)]$ is the open loop transfer function, is sketched, drawing the $\zeta=0.8$ line yields the complex poles at $-10 \pm j7.5$. The gain K_f , which equals 81.25, places the minor poles in a position to meet the specifications. The poles just found as well as the pole at the origin, act as openloop poles that generate a root locus for variations of the gain K . Similarly, the closed loop complex poles are found to be $-4.535 \pm j6.046$, with a required gain of 624.3. a third pole is at -10.93.

The result of simulation is shown in following figure. Figure shows the design specifications are met.

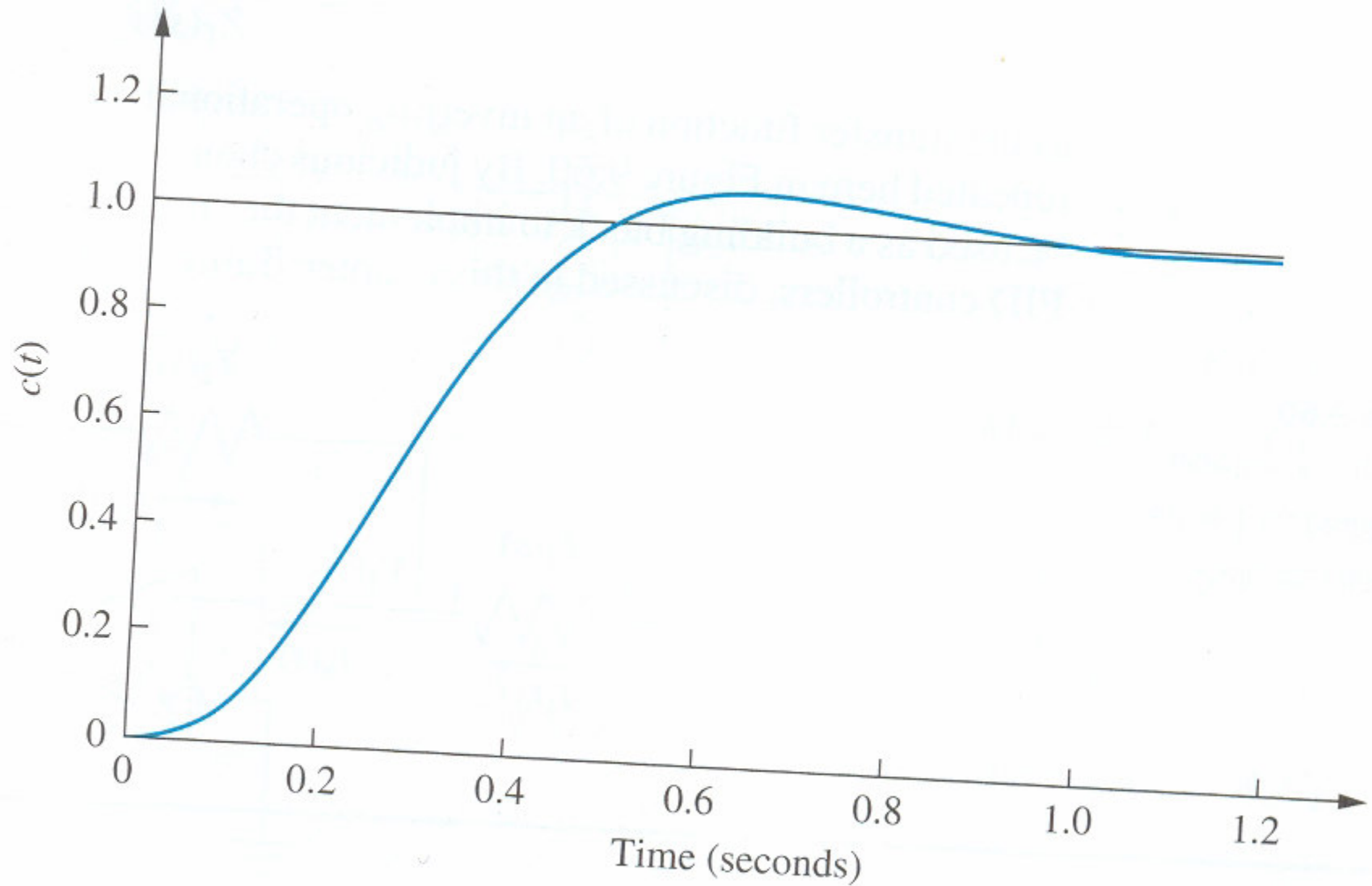

PHYSICAL REALIZATION OF COMPENSATION

We know the transfer function of an inverting operational amplifier whose configuration shown in figure is

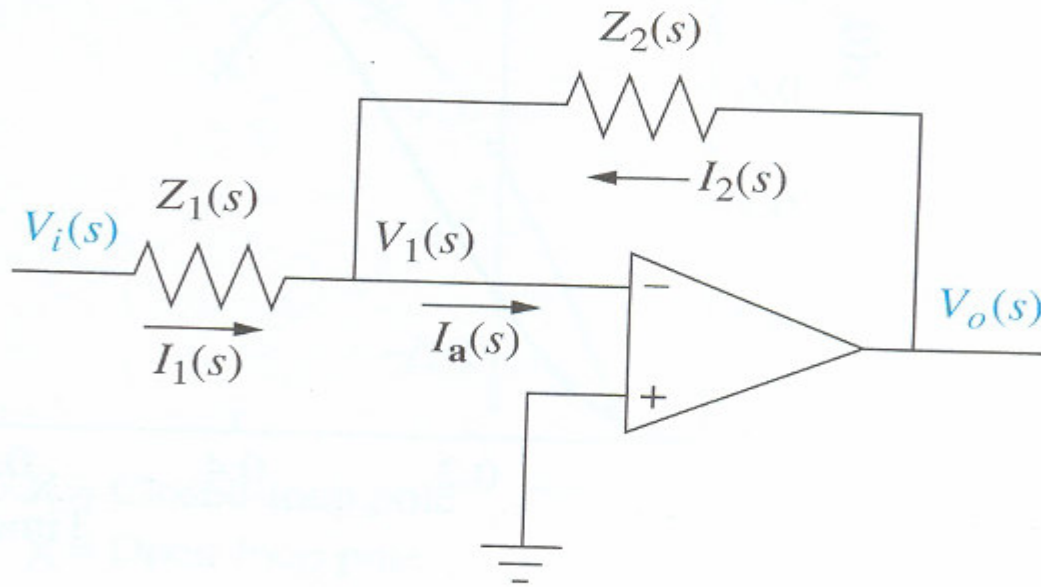







$$\frac{V_o(s)}{V_i(s)} = -\frac{Z_2(s)}{Z_1(s)}$$

By judicious choice of $Z_1(s)$ and $Z_2(s)$, this circuit can be used as a building block to implement the compensators, such as PID controller. Following table summarizes the realization of all controllers.

Other compensators can be realized by cascading compensators shown in table. For example, a lead-lag compensator can be formed by cascading the lead compensator with lag compensator.

Table 9.10 Active realization of controllers and compensators, using an operational amplifier

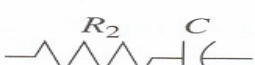
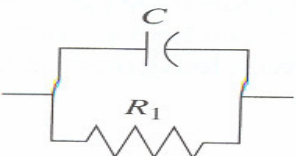
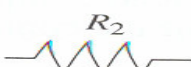
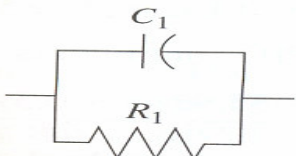
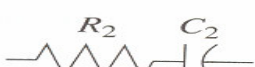
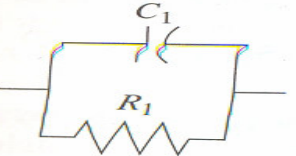
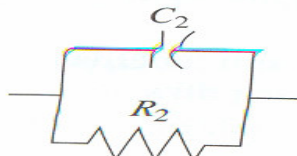
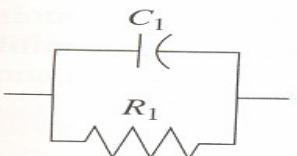
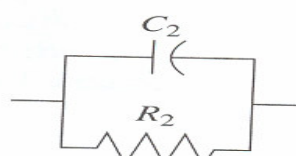
Function	$Z_1(s)$	$Z_2(s)$	$G_c(s) = -\frac{Z_2(s)}{Z_1(s)}$
Gain			$-\frac{R_2}{R_1}$
Integration			$-\frac{1}{RCs}$
Differentiation			$-RCs$
PI controller			$-\frac{R_2}{R_1} \left(s + \frac{1}{R_2 C} \right)$
PD controller			$-R_2 C \left(s + \frac{1}{R_1 C} \right)$
PID controller			$-\left[\left(\frac{R_2}{R_1} + \frac{C_1}{C_2} \right) + R_2 C_1 s + \frac{1}{R_1 C_2} \right]$
Lag compensation			$-\frac{C_1}{C_2} \left(\frac{s + \frac{1}{R_1 C_1}}{s + \frac{1}{R_2 C_2}} \right)$ where $R_2 C_2 > R_1 C_1$
Lead compensation			$-\frac{C_1}{C_2} \left(\frac{s + \frac{1}{R_1 C_1}}{s + \frac{1}{R_2 C_2}} \right)$ where $R_1 C_1 > R_2 C_2$

Example : Implement the PID controller has the transfer function $G_c(s) = \frac{(s+5592)(s+0.5)}{s}$

Solution : The transfer function of the controller can be put in the form

$$G_c(s) = s + 56.42 + \frac{27.96}{s}$$

Comparing the PID controller in the table, we obtain following three relationships :

$$\frac{R_2}{R_1} + \frac{C_1}{C_2} = 56.42, \quad R_2 C_1 = 1 \quad \text{and} \quad \frac{1}{R_1 C_2} = 27.96$$

Since there are four unknowns and three equations, we arbitrarily select a practical value for one of the elements. Selecting $C_2 = 0.1 \mu\text{F}$, the remaining values are found to be $R_1 = 357.65 \text{ k}\Omega$, $R_2 = 178.891 \text{ k}\Omega$ and $C_1 = 5.59 \mu\text{F}$. The complete circuit is shown in following figure, where the circuit element values have been rounded off.

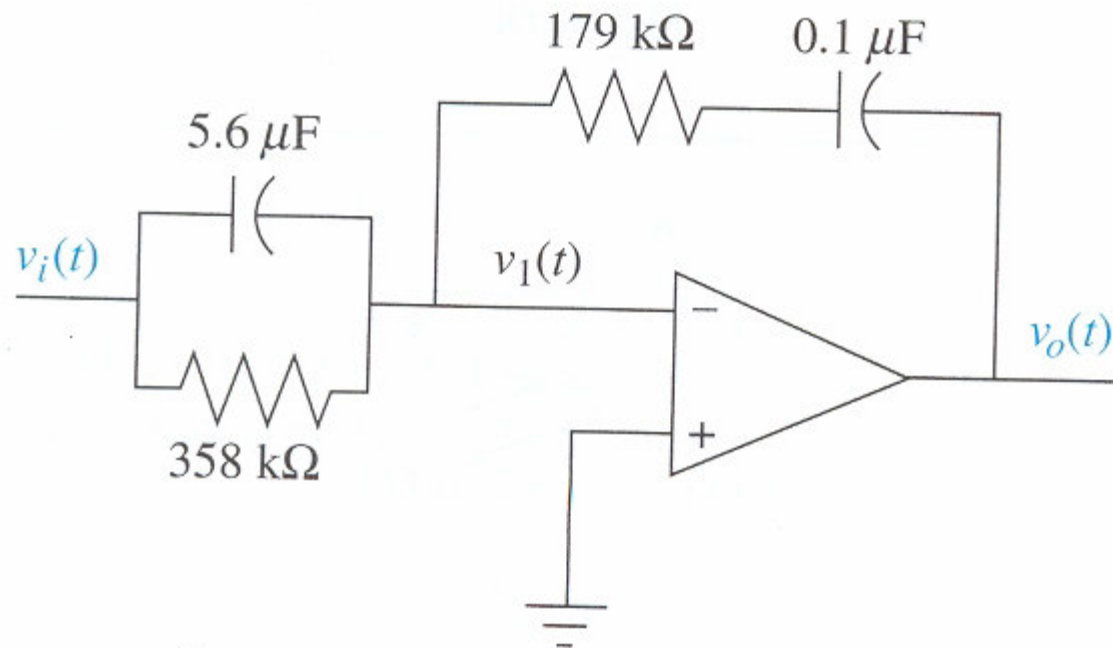

Passive circuit realization : Lag, lead, and lead lag compensators can also be implemented with passive network. Following table summarizes the networks and their transfer function.

Table 9.11 Passive realization of compensators

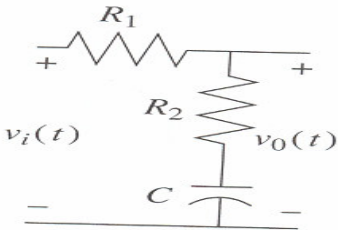
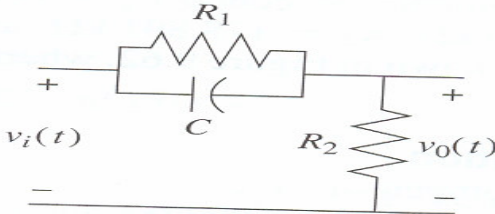
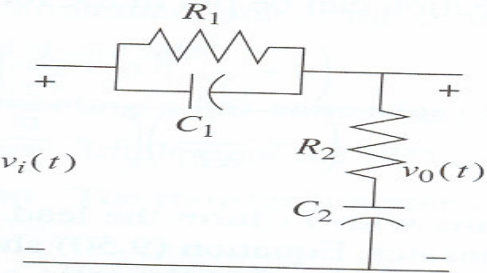
Function	Network	Transfer function, $\frac{V_o(s)}{V_i(s)}$
Lag compensation		$\frac{R_2}{R_1 + R_2} \frac{s + \frac{1}{R_2 C}}{s + \frac{1}{(R_1 + R_2) C}}$
Lead compensation		$\frac{s + \frac{1}{R_1 C}}{s + \frac{1}{R_1 C} + \frac{1}{R_2 C}}$
Lag-lead compensation		$\frac{\left(s + \frac{1}{R_1 C_1}\right)\left(s + \frac{1}{R_2 C_2}\right)}{s^2 + \left(\frac{1}{R_1 C_1} + \frac{1}{R_2 C_2} + \frac{1}{R_2 C_1}\right)s + \frac{1}{R_1 R_2 C_1 C_2}}$

Example : Realize the lead compensator has the transfer function $G_c = \frac{s + 4}{s + 20.09}$

Solution : Comparing the transfer function of a lead network shown in previous table with the compensator transfer function, we obtain the following relationships :

$$\frac{1}{R_1 C} = 4 \quad \text{and} \quad \frac{1}{R_1 C} + \frac{1}{R_2 C} = 20.09$$

Hence, $R_1 C = 0.25$ and $R_2 C = 0.0622$. Since there are three network elements and two equations, we may select one of the element values arbitrarily. Letting $C = 1 \mu\text{F}$, then $R_1 = 250 \text{ k}\Omega$ and $R_2 = 62.2 \text{ k}\Omega$.